



# CHINO BASIN WATERMASTER



## NOTICE OF MEETINGS

Thursday, April 15, 2010

9:00 a.m. – Advisory Committee Meeting

*AT THE CHINO BASIN WATERMASTER OFFICES  
9641 San Bernardino Road  
Rancho Cucamonga, CA 91730  
(909) 484-3888*





# **CHINO BASIN WATERMASTER**

**Thursday, April 15, 2010**

9:00 p.m. – Advisory Committee Meeting

## **AGENDA PACKAGE**



**CHINO BASIN WATERMASTER  
ADVISORY COMMITTEE MEETING**

9:00 a.m. – April 15, 2010

WITH

*Mr. Robert DeLoach, Chair, Appropriative Pool  
Mr. Bob Bowcock, Vice-Chair, Non-Agricultural Pool*

**At The Offices Of**

**Chino Basin Watermaster**  
9641 San Bernardino Road  
Rancho Cucamonga, CA 91730

**AGENDA**

**CALL TO ORDER**

**AGENDA - ADDITIONS/REORDER**

**I. CONSENT CALENDAR**

**Note:** All matters listed under the Consent Calendar are considered to be routine and non-controversial and will be acted upon by one motion in the form listed below. There will be no separate discussion on these items prior to voting unless any members, staff, or the public requests specific items be discussed and/or removed from the Consent Calendar for separate action.

**A. MINUTES**

1. Minutes of the Advisory Committee Meeting held March 18, 2010 *(Page 1)*

**B. FINANCIAL REPORTS**

1. Cash Disbursements for the month of February 2010 *(Page 7)*
2. Watermaster Visa Check Detail for the month of February 2010 *(Page 11)*
3. Combining Schedule for the Period July 1, 2009 through February 28, 2010 *(Page 13)*
4. Treasurer's Report of Financial Affairs for the Period February 1, 2010 through February 28, 2010 *(Page 15)*
5. Budget vs. Actual July 2009 through February 2010 *(Page 17)*

**II. BUSINESS ITEMS**

**A. AGREEMENT TO FORM A TASK FORCE**

Discussion Regarding of Agreement to Form a Task Force to Conduct the Annual Emerging Constituents Characterization Program for the Santa Ana River Watershed (Emerging Constituents Program). No Action is Required for April. Staff Will Provide Further Report and Seek Guidance from the Watermaster Board *(Page 19)*

**B. AMENDMENT NO. 1 TO AGREEMENT TO FORM A TASK FORCE**

Discussion Regarding Approval of Amendment No. 1 to Form a Task Force to Conduct a Basin Monitoring Program for Nitrogen and Total Dissolved Solids in the Santa Ana River Watershed (Basin Monitoring Program). No Action is Required for April. Staff Will Provide Further Report and Seek Guidance from the Watermaster Board *(Page 37)*

**III. REPORTS/UPDATES**

**A. WATERMASTER GENERAL LEGAL COUNSEL REPORT**

1. Paragraph 31 Motion Update
2. Database and Record Management

**C. CEO/STAFF REPORT**

1. Legislative Update
2. Recharge Update
3. Regional Board Complaint
4. San Sevaine 5 Berm Improvements

**D. INLAND EMPIRE UTILITIES AGENCY**

1. Recycled Water Recharge Program Update *(Page 47)*
2. MWD Water Rates and Budget Update - Oral
3. State Water Project Allocation Update - Oral
4. DYY Third Call Year - *Handout*
5. WSAP Second Allocation Year - *Handout*
6. Monthly Water Use Report - *Handout*
7. State and Federal Legislative Reports *(Page 71)*
8. Community Outreach/Public Relations Report *(Page 109)*
9. Peace II PEIR Schedule *(Page 111)*

**E. OTHER METROPOLITAN MEMBER AGENCY REPORTS**

**IV. INFORMATION**

1. Newspaper Articles *(Page 113)*

**V. COMMITTEE MEMBER COMMENTS**

**VI. OTHER BUSINESS**

**VII. CONFIDENTIAL SESSION - POSSIBLE ACTION**

Pursuant to the Advisory Committee Rules & Regulations, a Confidential Session may be held during the Watermaster Pool meeting for the purpose of discussion and possible action.

**VIII. FUTURE MEETINGS**

Thursday, April 15, 2010	8:00 a.m.	IEUA DYY Meeting @ CBWM
Thursday, April 15, 2010	9:00 a.m.	Advisory Committee Meeting @ CBWM
Wednesday, April 21, 2010	1:30 p.m.	* RMP Half Day Workshop @ <b>Rancho Central Park</b>
Thursday, April 22, 2010	11:00 a.m.	Watermaster Board Meeting @ CBWM
Thursday, May 6, 2010	1:00 p.m.	Appropriative Meeting @ CBWM
Thursday, May 6, 2010	2:30 p.m.	Non-Agricultural Pool Meeting @ CBWM
Thursday, May 13, 2010	9:00 a.m.	Agricultural Pool Meeting @ IEUA
Wednesday May 19, 2010	12:30 p.m.	* RMP Half Day Workshop @ <b>Rancho Central Park</b>
Thursday, May 20, 2010	8:00 a.m.	IEUA DYY Meeting @ CBWM
Thursday, May 20, 2010	9:00 a.m.	Advisory Committee Meeting @ CBWM
Thursday, May 27, 2010	11:00 a.m.	Watermaster Board Meeting @ CBWM

\* Recharge Master Plan (RMP) Workshop at Rancho Central Park  
11200 Base Line Road, Rancho Cucamonga

Meeting Adjourn



# CHINO BASIN WATERMASTER

## I. CONSENT CALENDAR

### A. MINUTES

1. Advisory Committee Meeting held on March 18, 2010



***Draft Minutes***  
**CHINO BASIN WATERMASTER**  
**ADVISORY COMMITTEE MEETING**  
*March 18, 2010*

The Advisory Committee meeting was held at the offices of the Chino Basin Watermaster, 9641 San Bernardino Road, Rancho Cucamonga CA, on March 18, 2010 at 9:00 a.m.

**ADVISORY COMMITTEE MEMBERS PRESENT WHO SIGNED IN**

**Appropriative Pool**

Robert DeLoach, Chair	Cucamonga Valley Water District
Ken Jeske	City of Ontario
Mark Kinsey	Monte Vista Water District
Dave Crosley	City of Chino
Bill Kruger	City of Chino Hills
Anthony La	City of Upland
Raul Garibay	City of Pomona
Tom Harder	Jurupa Community Services District
Charles Moorrees	San Antonio Water Company
Josh Swift	Fontana Union Water Company
Robert Young	Fontana Water Company
J. Arnold Rodriguez	Santa Ana River Water Company
Ben Lewis	Golden State Water Company

**Agricultural Pool**

Jeff Pierson	Ag Pool – Crops
Jennifer Novak	State of California Department of Justice
Pete Hall	State of California, CIM

**Non-Agricultural Pool**

Kevin Sage	Vulcan Materials Company (Calmat Division)
------------	--

**Watermaster Board Members Present**

Michael Camacho	Inland Empire Utilities Agency
-----------------	--------------------------------

**Watermaster Staff Present**

Ken Manning	CEO
Ben Pak	Senior Project Engineer
Danielle Maurizio	Senior Engineer
Sherri Lynne Molino	Recording Secretary

**Watermaster Consultants Present**

Michael Fife	Brownstein, Hyatt, Farber & Schreck
Mark Wildermuth	Wildermuth Environmental, Inc.

**Others Present Who Signed In**

Ron Craig	City of Chino Hills
Steve Nix	City of Chino Hills
John Mura	City of Chino Hills
Mike Maestas	City of Chino Hills
Marv Shaw	City of Ontario
Steven Lee	Reid & Hellyer
Ryan Shaw	Inland Empire Utilities Agency
Rich Atwater	Inland Empire Utilities Agency
Terry Catlin	Inland Empire Utilities Agency

Chris Berch  
Mike Sovich  
Marty Zvirbulis  
Gil Aldaco

Inland Empire Utilities Agency  
Three Valleys Municipal Water District  
Cucamonga Valley Water District  
City of Chino

Chair DeLoach called the Advisory Committee meeting to order at 9:03 a.m.

**AGENDA - ADDITIONS/REORDER**

Mr. Manning noted a revised agenda was distributed that added other Metropolitan Member Agencies under Reports/Updates.

**I. CONSENT CALENDAR**

**A. MINUTES**

1. Minutes of the Advisory Committee Meeting held February 18, 2010

**B. FINANCIAL REPORTS**

1. Cash Disbursements for the month of January 2010
2. Watermaster Visa Check Detail for the month of January 2010
3. Combining Schedule for the Period July 1, 2009 through January 31, 2010
4. Treasurer's Report of Financial Affairs for the Period January 1, 2010 through January 31, 2010
5. Budget vs. Actual July 2009 through January 2010

*Motion by Jeske, second by Kinsey, and by unanimous vote, Non-Agricultural Pool voted no  
**Moved to approve Consent Calendar item A and B, as presented***

**C. INTERVENTION INTO THE AGRICULTURAL POOL**

Intervention of Rafael Treto into the Agricultural Pool

*Motion by Jeske, second by Kinsey, and by unanimous vote  
**Moved to approve Consent Calendar item C, as presented***

**II. REPORTS/UPDATES**

**A. WATERMASTER GENERAL LEGAL COUNSEL REPORT**

**1. Peace II SEIR**

Counsel Fife stated this item is regarding the Peace II Supplemental Environmental Impact Report (SEIR) and was reported on at the Pool meetings. Counsel Fife stated the report is in its final stages of preparation and revisions are continuing to be made.

**2. Non-Agricultural Pool Information Requests Status**

Counsel Fife stated last week, legal counsel for Watermaster and legal counsel for the Appropriative Pool, met with the legal counsel for the Overlying Non-Agricultural Pool and reviewed the many information requests that were submitted over the last 30 days. Counsel Fife stated there is a handout on the back table regarding an account that Watermaster counsel provided to the Non-Agricultural Pool legal counsel and this table also shows what is still outstanding. Counsel Fife stated during this meeting legal counsel tried to give the Non-Ag legal counsel everything they had asked for. This item is to provide the parties with an update on this ongoing process. Mr. Garibay inquired about costs and expenses for this endeavor. Counsel Fife noted this is a Watermaster expense; however, all expenses are being separately tracked that are associated with this matter.

**3. Database and Record Management**

Counsel Fife stated while going through the Non-Agricultural Pool litigation process over the last 60 days, several administrative processes have been looked at that had not been looked at and/or reviewed in a long time. Counsel Fife stated counsel and staff has been assessing service lists, active parties' lists, etc. and in reviewing those types of lists, it has

been identified they are not all 100% up-to-date with name changes, deletions, or additions, etc. and with the creation of the new Policy Manual and the research being done regarding the information requests he noted this has been a useful exercise to see where shoring up needs to be done. Counsel Fife stated Watermaster records will be examined carefully to ensure that strict procedures are being complied with. Counsel Fife reviewed some of the areas that will be reviewed and updated including parties who need to become part of the Judgment through interventions. Mr. Manning commented on this upcoming endeavor for cleaning up Watermaster records, lists, and needed interventions. Counsel Fife noted the reason to address this now is so that the parties will know why there are so many interventions on upcoming agendas. This process will eventually include contacting parties from the Pools, Advisory Committee, and other committee member representatives and alternate representatives to be able to updated all Watermaster lists; this will be a full act to tighten up procedures.

## **B. ENGINEERING REPORT**

### **1. 2010 Basin Plan Amendment**

Mr. Wildermuth stated Wildermuth Environmental is a consultant to the Basin Monitoring Task Force and Andy Malone and he has been working on this project since 1996. Mr. Wildermuth stated Wildermuth Environmental is currently in the process of helping the task force help the Regional Board through the Basin Monitoring Task Force to update the Basin Plan. Mr. Wildermuth reviewed the Basin Plan Amendment Projects related to N/TDS Management Plan spreadsheet items #1 through #11 in detail and it was noted that the spreadsheet was put together by the Regional Board. Mr. Wildermuth reviewed #11 in greater detail because of the interest the City of Riverside has in it to change the nitrogen objective in Chino South. Mr. Wildermuth offered comment regarding changing objectives and how it affects the Chino Basin and its parties. Mr. Manning stated staff's recommendation to Wildermuth is for them to start working with Watermaster on developing a letter in opposition of this change. In writing that letter of opposition, Mr. Manning anticipates being able to have discussions regarding this situation. Mr. Manning noted Watermaster is not going to willingly absorb costs of others without talking about mitigating measures first. Mr. Manning discussed item #6 in detail and a brief discussion regarding cost differences ensued.

### **2. Recharge Master Plan Update**

Mr. Wildermuth stated Wildermuth has been working with Black & Veatch and Wagner & Bonsignore on the draft report. There is a workshop coming up that Bob Wagner is coming to and he will present storm water findings at that workshop.

## **C. CEO/STAFF REPORT**

### **1. Legislative Update**

Mr. Manning stated he was recently in Sacramento to attend the Inland Empire Legislative function and at that time he was able to go to the capital and meet with some members of the legislature. Mr. Manning noted he is the president of the California Groundwater Coalition and during his visit he was asked by assembly member Huffman, to co-sponsor AB2304. Mr. Manning explained the draft AB2304 in detail.

### **2. Recharge Update**

Mr. Manning stated January was a good month for recharge and noted 90% of recharge was from storm water. The most recent recharge spreadsheet is available on the back table for review. February appears to be a good month also for storm water capture for recharge.

### **3. ALCOA Monitoring Wells**

Mr. Manning stated this topic was discussed about a year or so ago. The ALCOA offsite wells were installed in 1999/2000 and there part of the offsite groundwater monitoring network. Those wells were monitoring the issue if migration of salt plums from ALCOA.



The Regional Board has determined the pollution has not reached the groundwater and has given ALCOA a No Further Action letter. Mr. Manning stated instead of ALCOA destroying the wells, Watermaster has been in discussions with them to try and take over those wells and that appears to be what will take place. Agreements are being worked on presently to transfer those wells over to Watermaster and are being defined as equipment. A discussion regarding these monitoring wells ensued.

4. Turner Basins/Guasti Park Task Force

Mr. Pak gave the Turner Basin/Guasti Park Demonstration Project presentation. Mr. Pak offered background history on this item. Mr. Pak noted a Technical Work Group has been formed which consists of San Bernardino County Park and Flood Control District, City of Rancho Cucamonga, City of Ontario, Chino Basin Watermaster, Chino Basin Water Conservation District, and Inland Empire Utilities Agency. Mr. Pak reviewed the preliminary concept and discussed the enhancement concepts. Mr. Pak discussed the implementation work plan schedule. Mr. Manning noted the schedule presented is a very aggressive schedule. Mr. Manning stated the plan is a very attractive plan in terms of attracting grant funds to the partnership mainly because of all the parties that are participating and the diverse interests are both being achieved within the plan and potential use by the public. A discussion regarding this project ensued.

**D. INLAND EMPIRE UTILITIES AGENCY**

1. Recycled Water Update

Mr. Atwater gave an executive summary on what took place at Dry Year Yield meeting this morning. Mr. Atwater stated there is a workshop scheduled for March 31, 2010, at 2:00 p.m. to discuss water supply conditions. Mr. Atwater reviewed the recycled water numbers.

Mr. Atwater stated there is a budget workshop scheduled for next Thursday with the Regional Sewage Committee on all our budgets and a board workshop on March 31, 2010, at 10:00 a.m. Mr. Atwater noted all the budget documents are on the IEUA website.

2. MWD Water Rates and Budget Update

Mr. Atwater stated on April 13, 2010 the Metropolitan Water District board is scheduled to approve both the rates effective January 1, 2011, and the Water Supply Allocation.

3. State Water Project Allocation Update

Mr. Atwater noted the State Water Project Allocation is still at 15%.

4. IEUA Monthly Water Newsletter

No comment was made regarding this item.

5. Monthly Water Use Report

No comment was made regarding this item.

6. State and Federal Legislative Reports

Mr. Atwater stated that the Regional Board did approve the water softener permit amendment for IEUA and here in the Chino Basin.

7. Community Outreach/Public Relations Report

Mr. Atwater stated the IEUA leadership breakfast is on March 23, 2010 at 7:30 a.m. at IEUA.

8. Peace II PEIR Schedule

No comment was made regarding this item.

Added Comment:

Mr. Atwater reviewed the handout dated June 14, 2009 regarding Bay Delta Conservation Plan Activities – JPL Decision Support Remote Sensing and Monitoring Opportunities in detail. A discussion regarding this matter ensued.

**F. OTHER METROPOLITAN MEMBER AGENCY REPORTS**

No comment was made regarding this item.

**III. INFORMATION**

1. Newspaper Articles

No comment was made regarding this item.

**IV. COMMITTEE MEMBER COMMENTS**

Mr. Kinsey stated when the parties change their Pool and Advisory representatives; they are supposed to notify Watermaster who the designated representative is going to be and their alternate. Mr. Kinsey stated Watermaster might send out a letter each year to all the parties asking to either confirm what staff already has or to supply Watermaster with the new names, addresses, and email addresses to keep records current.

Mr. Kinsey stated this notice is for the Appropriative Pool members who are present that there is a special Appropriative Pool closed session meeting held here at Watermaster on March 25, 2010, at 9:30 a.m.

**V. OTHER BUSINESS**

No comment was made regarding this item.

**VI. CONFIDENTIAL SESSION - POSSIBLE ACTION**

Pursuant to the Advisory Committee Rules & Regulations, a Confidential Session may be held during the Watermaster Pool meeting for the purpose of discussion and possible action.

No confidential session was held.

**VII. FUTURE MEETINGS**

Thursday, March 18, 2010	8:00 a.m.	IEUA DYY Meeting @ CBWM
Thursday, March 18, 2010	9:00 a.m.	Advisory Committee Meeting @ CBWM
Thursday, March 18, 2010	2:00 p.m.	MZ1 Technical Committee Meeting @ CBWM
Thursday, March 25, 2010	11:00 a.m.	Watermaster Board Meeting @ CBWM
Thursday, March 25, 2010	1:00 p.m.	Recharge Master Plan Workshop @ CBWM
Thursday, April 8, 2010	9:00 a.m.	Agricultural Pool Meeting @ IEUA
* Thursday, April 8, 2010	1:00 p.m.	Appropriative Meeting @ CBWM
* Thursday, April 8, 2010	2:30 p.m.	Non-Agricultural Pool Meeting @ CBWM
Thursday, April 15, 2010	8:00 a.m.	IEUA DYY Meeting @ CBWM
Thursday, April 15, 2010	9:00 a.m.	Advisory Committee Meeting @ CBWM
Wednesday April 21, 2010	9:00 a.m.	RMP Half Day Workshop @ Rancho Central Park
Thursday, April 22, 2010	11:00 a.m.	Watermaster Board Meeting @ CBWM

\* Notes a different day than the regularly scheduled 1<sup>st</sup> Thursday of every month meeting and will return to the normal schedule on May 6, 2010

The Advisory Committee meeting was dismissed by Chair DeLoach at 9:45 a.m.

Secretary: \_\_\_\_\_

Minutes Approved: \_\_\_\_\_



# CHINO BASIN WATERMASTER

## I. CONSENT CALENDAR

### B. FINANCIAL REPORTS

1. Cash Disbursements for the month of February 2010
2. Watermaster Check Detail for the month of February 2010
3. Combining Schedule for the Period July 1, 2009 through February 28, 2010
4. Treasurer's Report of Financial Affairs for the Period February 1, 2010 through February 28, 2010
5. Budget vs. Actual July 2009 through February 2010





# CHINO BASIN WATERMASTER

9641 San Bernardino Road, Rancho Cucamonga, Ca 91730  
Tel: 909.484.3888 Fax: 909.484.3890 www.cbwm.org

---

KENNETH R. MANNING  
Chief Executive Officer

## STAFF REPORT

**DATE:** April 15, 2010  
**TO:** Committee Members  
**SUBJECT:** Cash Disbursement Report

### SUMMARY

**Issue** – Record of cash disbursements for the month of February 2010.

**Recommendation** – Staff recommends the Cash Disbursements for February 2010 be received and filed as presented.

**Fiscal Impact** – Funds disbursed were included in the FY 2009-2010 Watermaster Budget.

### BACKGROUND

A monthly cash disbursement report is provided to keep all members apprised of Watermaster expenditures.

### DISCUSSION

Total cash disbursements during the month of February 2010 were \$446,915.62. The most significant expenditures during the month were Wildermuth Environmental, Inc. in the amount of \$193,511.15 and Brownstein Hyatt Farber Schreck in the amount of \$45,705.27.

### Actions:

- 4-08-10 Appropriative Pool – Unanimously Approved
- 4-08-10 Non-Agricultural Pool – Pulled
- 4-08-10 Agricultural Pool – Unanimously Approved
- 4-15-10 Advisory Committee –
- 4-22-10 Watermaster Board –

THIS PAGE  
HAS  
INTENTIONALLY  
BEEN LEFT  
BLANK  
FOR PAGINATION

CHINO BASIN WATERMASTER  
Cash Disbursement Detail Report  
February 2010

Feb 10

Type	Date	Num	Name	Amount
Bill Pmt -Check	02/03/2010	13903	AMERICAN GROUND WATER TRUST	-1,175.00
Bill Pmt -Check	02/03/2010	13904	APPLIED COMPUTER TECHNOLOGIES	-2,883.50
Bill Pmt -Check	02/03/2010	13905	ARROWHEAD MOUNTAIN SPRING WATER	-11.95
Bill Pmt -Check	02/03/2010	13906	BLACK & VEATCH CORPORATION	-3,367.50
Bill Pmt -Check	02/03/2010	13907	BROWNSTEIN HYATT FARBER SCHRECK	-45,705.27
Bill Pmt -Check	02/03/2010	13908	DEPARTMENT OF HEALTH SERVICES	-170.00
Bill Pmt -Check	02/03/2010	13909	DIRECTV	-83.99
Bill Pmt -Check	02/03/2010	13910	HSBC BUSINESS SOLUTIONS	-344.57
Bill Pmt -Check	02/03/2010	13911	JAMES JOHNSTON	-900.00
Bill Pmt -Check	02/03/2010	13912	KONICA MINOLTA BUSINESS SOLUTIONS	-269.20
Bill Pmt -Check	02/03/2010	13913	MET LIFE SMALL BUSINESS CENTER	-50.00
Bill Pmt -Check	02/03/2010	13914	MWH LABORATORIES	-1,450.00
Bill Pmt -Check	02/03/2010	13915	OFFICE DEPOT	-162.96
Bill Pmt -Check	02/03/2010	13916	PURCHASE POWER	-461.09
Bill Pmt -Check	02/03/2010	13917	R&D PEST SERVICES	-85.00
Bill Pmt -Check	02/03/2010	13918	REID & HELLYER	-7,127.79
Bill Pmt -Check	02/03/2010	13919	RUTH CAZDEN	-800.00
Bill Pmt -Check	02/03/2010	13920	VERIZON	-751.70
Bill Pmt -Check	02/03/2010	13921	VISION SERVICE PLAN	-64.98
Bill Pmt -Check	02/03/2010	13922	W.C. DISCOUNT MOBILE AUTO DETAILING	-100.00
Bill Pmt -Check	02/03/2010	13923	MWH LABORATORIES	-11,612.00
Bill Pmt -Check	02/03/2010	13924	WILDERMUTH ENVIRONMENTAL INC	-193,511.15
Bill Pmt -Check	02/03/2010	13925	YUKON DISPOSAL SERVICE	-142.88
Bill Pmt -Check	02/03/2010	13926	CITISTREET	-1,838.34
Bill Pmt -Check	02/03/2010	13927	PUBLIC EMPLOYEES' RETIREMENT SYSTEM	-3,740.95
Bill Pmt -Check	02/03/2010	13928	CITISTREET	-1,838.34
Bill Pmt -Check	02/03/2010	13929	PUBLIC EMPLOYEES' RETIREMENT SYSTEM	-7,117.08
Bill Pmt -Check	02/03/2010	13930	CITISTREET	-2,038.34
Bill Pmt -Check	02/03/2010	13931	PUBLIC EMPLOYEES' RETIREMENT SYSTEM	-7,114.66
Bill Pmt -Check	02/03/2010	13932	PUBLIC EMPLOYEES' RETIREMENT SYSTEM	-7,143.70
Bill Pmt -Check	02/03/2010	13933	PUBLIC EMPLOYEES' RETIREMENT SYSTEM	-7,136.48
Bill Pmt -Check	02/05/2010	13934	BOWCOCK, ROBERT	-125.00
Bill Pmt -Check	02/05/2010	13935	CAMACHO, MICHAEL	-500.00
Bill Pmt -Check	02/05/2010	13936	CHARLES MEISNER INC.	0.00
Bill Pmt -Check	02/05/2010	13937	GUARANTEED JANITORIAL SERVICE, INC.	-865.00
Bill Pmt -Check	02/05/2010	13938	HAUGHEY, TOM	-125.00
Bill Pmt -Check	02/05/2010	13939	KUHN, BOB	-250.00
Bill Pmt -Check	02/05/2010	13940	PACIFIC PARTS AND CONTROLS, INC	-95.91
Bill Pmt -Check	02/05/2010	13941	PAYCHEX	-341.22
Bill Pmt -Check	02/05/2010	13942	PETTY CASH	-387.21
Bill Pmt -Check	02/05/2010	13943	POWERS ELECTRIC PRODUCTS CO.	-500.25
Bill Pmt -Check	02/05/2010	13944	SOLINST CANADA LTD.	-117.50
Bill Pmt -Check	02/05/2010	13945	STATE COMPENSATION INSURANCE FUND	-847.85
Bill Pmt -Check	02/05/2010	13946	UNION 76	-248.72

CHINO BASIN WATERMASTER  
Cash Disbursement Detail Report  
February 2010

Type	Date	Num	Name	Amount
Bill Pmt -Check	02/05/2010	13947	VANDEN HEUVEL, GEOFFREY	-125.00
Bill Pmt -Check	02/05/2010	13948	WHITEHEAD, MICHAEL	-125.00
Bill Pmt -Check	02/05/2010	13949	WILLIS, KENNETH	-375.00
General Journal	02/06/2010	100108	PAYROLL 01/24/10-02/06/10	-6,558.11
General Journal	02/06/2010	100108	PAYROLL 01/24/10-02/06/10	-24,960.80
Bill Pmt -Check	02/09/2010	13950	PARK PLACE COMPUTER SOLUTIONS, INC.	-2,400.00
Bill Pmt -Check	02/10/2010	13951	CHARLES MEISNER INC.	-151.90
Bill Pmt -Check	02/16/2010	13952	BANC OF AMERICA LEASING	-3,215.74
Bill Pmt -Check	02/16/2010	13953	CINDY NAVAROLI	-750.00
Bill Pmt -Check	02/16/2010	13954	COMPUTER NETWORK	-449.91
Bill Pmt -Check	02/16/2010	13955	CUCAMONGA VALLEY WATER DISTRICT	-5,792.00
Bill Pmt -Check	02/16/2010	13956	FIRST AMERICAN REAL ESTATE SOLUTIONS	-125.00
Bill Pmt -Check	02/16/2010	13957	g.Neil	-57.99
Bill Pmt -Check	02/16/2010	13958	INLAND EMPIRE UTILITIES AGENCY	-10,000.00
Bill Pmt -Check	02/16/2010	13959	MCI	-1,237.85
Bill Pmt -Check	02/16/2010	13960	MWH LABORATORIES	-351.00
Bill Pmt -Check	02/16/2010	13961	SAFEGUARD DENTAL & VISION	-7.68
Bill Pmt -Check	02/16/2010	13962	SOFTCHOICE	-1,844.57
Bill Pmt -Check	02/16/2010	13963	STAULA, MARY L	-136.61
Bill Pmt -Check	02/16/2010	13964	THE STANDARD INSURANCE COMPANY	-156.56
Bill Pmt -Check	02/16/2010	13965	VERIZON WIRELESS	-525.31
Bill Pmt -Check	02/16/2010	13966	W.C. DISCOUNT MOBILE AUTO DETAILING	-100.00
Bill Pmt -Check	02/16/2010	13967	WESTERN DENTAL SERVICES, INC.	-28.06
Bill Pmt -Check	02/17/2010	13968	COMPUTER NETWORK	-402.38
General Journal	02/20/2010	100110	PAYROLL 02/07/10-02/20/10	-7,052.99
General Journal	02/20/2010	100110	PAYROLL 02/07/10-02/20/10	-26,372.78
Bill Pmt -Check	02/24/2010	13969	ACWA SERVICES CORPORATION	-230.79
Bill Pmt -Check	02/24/2010	13970	BANK OF AMERICA	-2,528.68
Bill Pmt -Check	02/24/2010	13971	CITISTREET	-1,020.00
Bill Pmt -Check	02/24/2010	13972	COMPUTER NETWORK	-271.88
Bill Pmt -Check	02/24/2010	13973	PRE-PAID LEGAL SERVICES, INC.	-103.60
Bill Pmt -Check	02/24/2010	13974	PREMIERE GLOBAL SERVICES	-832.99
Bill Pmt -Check	02/24/2010	13975	PUBLIC EMPLOYEES' RETIREMENT SYSTEM	-7,141.30
Bill Pmt -Check	02/24/2010	13976	RAUCH COMMUNICATION CONSULTANTS, LLC	-8,600.00
Bill Pmt -Check	02/24/2010	13977	UNITED PARCEL SERVICE	-12.81
Bill Pmt -Check	02/24/2010	13978	ROJO, SHERI M	-1,489.80
Bill Pmt -Check	02/24/2010	13979	ROJO, SHERI M	-13,531.02
Bill Pmt -Check	02/24/2010	13980	ROJO, SHERI M	-4,248.43
				<b><u>-446,915.62</u></b>

Feb 10



9:49 AM  
03/31/10

CHINO BASIN WATERMASTER  
Check Detail  
February 2010

Type	Num	Date	Name	Account	Paid Amount
Bill Pmt -Ch...	13970	2/24/2010	BANK OF AMER...	1012 · Bank of America Gen'l Ckg	
Bill	4024...	1/31/2010		6909.1 · OBMP Meetings	-455.17
				6191 · Conferences	-1,127.20
				6312 · Meeting Expenses	-570.35
				6141.3 · Admin Meetings	-185.96
				6043.1 · Ricoh Lease Fee	-190.00
TOTAL					-2,528.68

THIS PAGE  
HAS  
INTENTIONALLY  
BEEN LEFT  
BLANK  
FOR PAGINATION

CHINO BASIN WATERMASTER  
COMBINING SCHEDULE OF REVENUE, EXPENSES AND CHANGES IN WORKING CAPITAL  
FOR THE  
PERIOD JULY 1, 2009 THROUGH FEBRUARY 28, 2010

	WATERMASTER ADMINISTRATION	OPTIMUM BASIN MANAGEMENT	POOL APPROPRIATIVE POOL	AG POOL	NON-AG POOL	GROUNDWATER REPLENISHMENT	GROUNDWATER OPERATIONS SB222 FUNDS	EDUCATION FUNDS	GRAND TOTALS	BUDGET 2009-2010
Administrative Revenues:										
Administrative Assessments			7,115,654	-	325,016				7,440,670	\$7,340,839
Interest Revenue			18,677	1,425	842			3	20,947	191,540
Mutual Agency Project Revenue			-	-	-				-	148,410
Grant Income			-	-	-				-	0
Miscellaneous Income			188	-	-				111,188	0
Total Revenues	111,000		7,134,520	1,425	325,858			3	7,572,806	7,680,789
Administrative & Project Expenditures:										
Watermaster Administration	444,190								444,190	580,238
Watermaster Board-Advisory Committee	39,903								39,903	61,901
Pool Administration			16,198	92,469	6,906				115,572	229,860
Optimum Basin Mgmt Administration		920,211							920,211	1,557,820
OBMP Project Costs		2,578,274							2,578,274	4,109,362
Debt Service		567,042							567,042	1,131,233
Education Funds Use										375
Mutual Agency Project Costs										10,000
Total Administrative/OBMP Expenses	484,093	4,065,526	16,198	92,469	6,906				4,665,191	7,680,789
Net Administrative/OBMP Expenses	(373,093)	(4,065,526)								
Allocate Net Admin Expenses To Pools			260,670	98,902	13,520					
Allocate Net OBMP Expenses To Pools			2,444,300	927,406	126,779					
Allocate Debt Service to App Pool			567,042							
Agricultural Expense Transfer*			1,118,777	(1,118,777)						
Total Expenses	4,406,987				147,204				4,665,191	7,680,789
Net Administrative Income	2,727,533		1,425		178,654			3	2,907,614	-
Other Income/(Expense)										
Replenishment Water Assessments						7,073,805			7,073,805	0
Interest Revenue						13,504			13,504	0
Water Purchases										0
Balance Adjustment										0
Other Water Purchases						(2,166,022)			(2,166,022)	0
Groundwater Replenishment						(1,021,346)			(1,021,346)	0
Net Other Income						3,899,940			3,899,940	0
Net Transfers To/(From) Reserves	6,807,554		2,727,533	1,425	178,654	3,899,940		3	6,807,554	-
Working Capital, July 1, 2009			5,942,967	470,719	256,577	4,166,457	158,251	995	10,995,966	
Working Capital, End Of Period			8,670,500	472,144	435,231	8,066,397	158,251	998	17,803,520	17,803,520
08/09 Assessable Production			84,716,450	32,142,764	4,393,990				121,253,204	
08/09 Production Percentages			69.867%	26.509%	3.624%				100.000%	

\*Fund balance transfer as agreed to in the Peace Agreement.

0:\Financial Statements\09-10\10-02\Combining February.rptsheet

Prepared by Todd M. Corbin, Interim Chief Financial Officer

THIS PAGE  
HAS  
INTENTIONALLY  
BEEN LEFT  
BLANK  
FOR PAGINATION

**CHINO BASIN WATERMASTER  
TREASURER'S REPORT OF FINANCIAL AFFAIRS FOR THE PERIOD  
FEBRUARY 1 THROUGH FEBRUARY 28, 2010**

<b>DEPOSITORIES:</b>		
Cash on Hand - Petty Cash	\$	500
Bank of America		
Governmental Checking-Demand Deposits	\$	936,343
Zero Balance Account - Payroll		
Local Agency Investment Fund - Sacramento		17,394,199
		<hr/>
<b>TOTAL CASH IN BANKS AND ON HAND</b>		<b>2/28/2010</b>
<b>TOTAL CASH IN BANKS AND ON HAND</b>		<b>1/31/2010</b>
	\$	18,331,042
		18,728,817
	\$	<u><u>(397,775)</u></u>

**CHANGE IN CASH POSITION DUE TO:**

Decrease/(Increase) in Assets:		
Accounts Receivable	\$	39,700
Assessments Receivable		(90,584)
Prepaid Expenses, Deposits & Other Current Assets		-
(Decrease)/Increase in Liabilities		(18,549)
Accounts Payable		-
Accrued Payroll, Payroll Taxes & Other Current Liabilities		-
Transfer to/(from) Reserves		<u>(328,342)</u>
	\$	<u><u>(397,775)</u></u>

**SUMMARY OF FINANCIAL TRANSACTIONS:**

Balances as of 1/31/2010						
Deposits	\$	1,334,118	\$	-	\$	17,394,199
Transfers		49,141		-		-
Withdrawals/Checks		(64,945)		64,945		-
		(381,971)		(64,945)		-
		<u>(446,916)</u>				<u>(446,916)</u>
Balances as of 2/28/2010	\$	500	\$	936,343	\$	17,394,199
		-		-		-
	\$	<u><u>(397,775)</u></u>	\$	-	\$	<u><u>(397,775)</u></u>

CHINO BASIN WATERMASTER  
 TREASURER'S REPORT OF FINANCIAL AFFAIRS FOR THE PERIOD  
 FEBRUARY 1 THROUGH FEBRUARY 28, 2010

INVESTMENT TRANSACTIONS

Effective Date	Transaction	Depository	Activity	Redeemed	Days to Maturity	Interest Rate(*)	Maturity Yield
***No transactions to report***							

TOTAL INVESTMENT TRANSACTIONS \$ -

\* The earnings rate for L.A.I.F. is a daily variable rate; 0.6% was the effective yield rate at the Quarter ended December 31, 2009.

INVESTMENT STATUS  
 February 28, 2010

Financial Institution	Principal Amount	Number of Days	Interest Rate	Maturity Date
Local Agency Investment Fund	\$ 17,394,199			
<b>TOTAL INVESTMENTS</b>	<b>\$ 17,394,199</b>			

Funds on hand are sufficient to meet all foreseen and planned Administrative and project expenditures during the next six months.

All investment transactions have been executed in accordance with the criteria stated in Chino Basin Watermaster's Investment Policy.

Respectfully submitted,



Todd M. Corbin  
 Interim Chief Financial Officer  
 Chino Basin Watermaster

CHINO BASIN WATERMASTER  
Profit Loss Budget vs. Actual  
July 2009 through February 2010

	YTD Actuals 7/09 - 2/10	FY 2009-10 Budget	SAmt Over (Under) Budget	% of Budget
<b>Ordinary Income/Expense</b>				
<b>Income</b>				
4010 · Local Agency Subsidies	111,000	148,410	-37,410	75%
4110 · Admin Asmnts-Approp Pool	7,115,654	7,185,411	-69,757	99%
4120 · Admin Asmnts-Non-Agri Pool	325,016	155,427	169,589	209%
4700 · Non Operating Revenues	20,947	191,540	-170,593	11%
4900 · Miscellaneous income	188			
<b>Total Income</b>	<b>7,572,806</b>	<b>7,680,788</b>	<b>-107,982</b>	<b>99%</b>
<b>Gross Profit</b>	<b>7,572,806</b>	<b>7,680,788</b>	<b>-107,982</b>	<b>99%</b>
<b>Expense</b>				
6010 · Salary Costs	337,305	487,836	-150,533	69%
6020 · Office Building Expense	64,425	102,500	-38,075	63%
6030 · Office Supplies & Equip.	21,090	43,500	-22,410	48%
6040 · Postage & Printing Costs	46,539	84,300	-37,761	55%
6050 · Information Services	84,923	148,500	-63,577	57%
6060 · Contract Services	103,949	98,000	5,949	106%
6080 · Insurance	15,934	16,730	-796	95%
6110 · Dues and Subscriptions	17,670	17,000	670	104%
6140 · WM Admin Expenses	2,230	3,000	-770	74%
6150 · Field Supplies	271	2,800	-2,529	10%
6170 · Travel & Transportation	18,206	37,800	-19,594	48%
6190 · Conferences & Seminars	15,611	26,500	-10,889	59%
6200 · Advisory Comm - WM Board	12,842	18,078	-5,236	71%
6300 · Watermaster Board Expenses	27,061	43,823	-16,762	62%
8300 · Appr PI-WM & Pool Admin	16,198	23,069	-6,871	70%
8400 · Agri Pool-WM & Pool Admin	19,162	25,114	-5,952	76%
8467 · Ag Legal & Technical Services	66,557	98,000	-31,443	68%
8470 · Ag Meeting Attend -Special	6,750	12,000	-5,250	56%
8471 · Ag Pool Expense	0	65,000	-65,000	0%
8500 · Non-Ag PI-WM & Pool Admin	6,906	6,677	229	103%
6500 · Education Funds Use Expens	0	375	-375	0%
9500 · Allocated G&A Expenditures	-283,963	-488,230	204,267	58%
	599,665	872,374	-272,709	69%
6900 · Optimum Basin Mgmt Plan	830,815	1,399,371	-568,556	59%
6950 · Mutual Agency Projects	0	10,000	-10,000	0%
9501 · G&A Expenses Allocated-OBMP	89,395	148,448	-59,053	60%
	920,211	1,557,819	-637,608	59%

CHINO BASIN WATERMASTER  
Profit Loss Budget vs. Actual  
July 2009 through February 2010

	YTD Actuals 7/09 - 2/10	FY 2009-10 Budget	\$Amt Over (Under) Budget	% of Budget
7101 · Production Monitoring	62,960	107,047	-44,087	59%
7102 · In-line Meter Installation	25,413	56,179	-30,766	45%
7103 · Grdwtr Quality Monitoring	137,910	214,362	-76,452	64%
7104 · Gdwtr Level Monitoring	225,094	366,956	-141,862	61%
7105 · Sur Wtr Qual Monitoring	3,679	43,912	-40,233	8%
7107 · Ground Level Monitoring	138,979	550,059	-411,080	25%
7108 · Hydraulic Control Monitoring	307,195	567,022	-259,827	54%
7109 · Recharge & Well Monitoring Prog	3,668	9,152	-5,485	40%
7200 · PE2- Comp Recharge Pgm	1,220,997	1,478,560	-257,563	83%
7300 · PE3&5-Water Supply/Desalte	41,816	96,003	-54,187	44%
7400 · PE4- Mgmt Plan	68,292	91,985	-23,693	74%
7500 · PE6&7-CoopEfforts/SaltMgmt	117,672	163,727	-46,055	72%
7600 · PE8&9-StorageMgmt/Conj Use	30,032	29,550	482	102%
7690 · Recharge Improvement Debt Pymt	567,042	1,131,233	-564,191	50%
7700 · Inactive Well Protection Prgm	0	5,066	-5,066	0%
9502 · G&A Expenses Allocated-Projects	194,568	339,782	-145,214	57%
	<u>3,145,316</u>	<u>5,250,595</u>	<u>-2,105,279</u>	<u>60%</u>
<b>Total Expense</b>	<u>4,655,191</u>	<u>7,680,788</u>	<u>-3,015,597</u>	<u>61%</u>
<b>Net Ordinary Income</b>	2,907,614		2,907,614	100%
<b>Other Income/Expense</b>				
<b>Other Income</b>				
4225 · Interest Income	13,504			
4210 · Approp Pool-Replenishment	4,887,364			
4220 · Non-Ag Pool-Replenishment	9,478			
4600 · Groundwater Sales	2,176,962			
<b>Total Other Income</b>	<u>7,087,308</u>			
<b>Other Expense</b>				
5010 · Groundwater Replenishment	1,021,346			
5100 · Other Water Purchases	2,166,022			
9999 · To/(From) Reserves	6,807,554			
<b>Total Other Expense</b>	<u>9,994,923</u>			
<b>Net Other Income</b>	<u>-2,907,614</u>			
<b>Net Income</b>	<u>0</u>		<u>0</u>	<u>0%</u>





# CHINO BASIN WATERMASTER

## II. BUSINESS ITEM

### A. AGREEMENT TO FORM A TASK FORCE

Consider Approval of Agreement to Form a Task Force to Conduct the Annual Emerging Constituents Characterization Program for the Santa Ana River Watershed (Emerging Constituents Program)





# CHINO BASIN WATERMASTER

9641 San Bernardino Road, Rancho Cucamonga, Ca 91730  
Tel: 909.484.3888 Fax: 909.484.3890 www.cbwm.org

---

KENNETH R. MANNING  
Chief Executive Officer

## STAFF REPORT

**DATE:** April 8, 2010  
**TO:** Committee Members  
**SUBJECT:** Agreement to Form a Task Force to Conduct the Annual Emerging Constituents Characterization Program for the Santa Ana River Watershed (Emerging Constituents Program)

### SUMMARY

**Recommendation** – No Action is Required for April. Staff Will Provide Further Report and Seek Guidance from the Watermaster Board

**Financial Impact** - Annual budget is prepared by the Task Force and its pro-rata share of such costs and fees are shared among the TASK FORCE AGENCIES. The budget proposed for the fiscal year 2010/11 is \$87,500 and the Watermaster's share is \$2,500.

### BACKGROUND

A workgroup of water resource agencies in the Santa Ana Watershed was formed in April 2008 to work cooperatively with the Santa Ana Regional Board in investigating emerging constituents "unregulated chemicals" and determine which emerging constituents may be important to assure water quality protection in the Santa Ana River Watershed. The formation of this workgroup was prompted by a cooperative agreement signed in January 2008 among imported water recharging agencies and the Regional Board, to assure water quality protection resulting from imported water recharge in the Santa Ana Watershed. An evaluation of emerging constituents was proposed under a two-phase work approach. Under the first phase, the workgroup met regularly to define the purpose of an emerging constituents investigation program, to review the lessons learned from past and present emerging constituents monitoring programs, to survey the technical capability of well-qualified commercial laboratories to analyze for emerging constituents, and to identify the potential regulatory issues that may arise as a result of collecting and publishing emerging constituent data. A Phase I report was completed and forwarded to the Regional Board in December 2008. Thereafter, under Phase II, the workgroup met monthly to develop a long-term characterization program for emerging constituents and to define requirements for the submittal of an annual report based on sampling conducted for specific emerging

constituents in the Santa Ana region. The Phase II report was completed and submitted to the Regional Board for approval in December 2009.

As defined in the Phase II report, the workgroup designated the Santa Ana Watershed Project Authority (SAWPA) as the lead agency to prepare an annual emerging constituents report for submittal to the Regional Board based on sampling and laboratory analysis data submitted by the TASK FORCE AGENCIES and other cooperating agencies to SAWPA.

The purpose of this Task Force Agreement is to form a task force to oversee and conduct the necessary annual report for the Emerging Constituents Characterization program as defined in the SAWPA Phase II Emerging Constituents Work plan approved by the Regional Board on December 10, 2009. The Task Force is proposed to consist of the TASK FORCE AGENCIES to direct the study and fund it on an equitable basis to be determined by the Task Force.

**Actions:**

- April 8, 2010 Appropriative Pool – Discussion Only
- April 8, 2010 Non-Agricultural Pool – Discussion Only
- April 8, 2010 Agricultural Pool – Discussion Only
- April 15, 2010 Advisory Committee –
- April 22, 2010 Watermaster Board –

**AGREEMENT TO FORM A TASK FORCE  
TO CONDUCT THE ANNUAL EMERGING CONSTITUENTS CHARACTERIZATION  
PROGRAM FOR THE SANTA ANA RIVER WATERSHED  
(EMERGING CONSTITUENTS PROGRAM)**

**THIS AGREEMENT** is made and entered into this \_\_\_th day of \_\_\_\_\_, 2010 by and among the following entities, which hereinafter are sometimes referred to collectively as "TASK FORCE AGENCIES" or individually as "TASK FORCE AGENCY" ("AGREEMENT"). This AGREEMENT is also by and between the Santa Ana Watershed Project Authority ("SAWPA") and the TASK FORCE AGENCIES as to SAWPA's role as Task Force Administrator. The following public agencies are the "TASK FORCE AGENCIES":

- Eastern Municipal Water District
- Inland Empire Utilities Agency
- Orange County Water District
- San Bernardino Valley Muni Water District
- Western Municipal Water District
- Elsinore Valley Municipal Water District
- Irvine Ranch Water District
- Jurupa Community Services District
- Lee Lake Water District
- Metropolitan Water District of Southern California
- San Geronio Pass Water Agency
- Yucaipa Valley Water District
- City of Beaumont
- City of Corona
- City of Redlands
- City of Rialto
- City of Riverside
- Chino Basin Watermaster
- Colton/San Bernardino Regional Tertiary Treatment and Wastewater Reclamation Authority
- Western Riverside County Regional Wastewater Authority

**I. RECITALS**

A. **Background.** In April 2008, a workgroup of water resource agencies in the Santa Ana Watershed was convened by the Santa Ana Watershed Project Authority to work cooperatively with the Santa Ana Regional Board in investigating emerging constituents "unregulated chemicals" and determine which emerging constituents may be important to assure water quality protection in the Santa Ana River Watershed. The formation of this workgroup was prompted by a cooperative agreement signed in January 2008 among imported water recharging agencies and the Regional Board, to assure water quality protection resulting from imported water recharge in the Santa Ana Watershed. An evaluation of emerging constituents was proposed under a two-phase work approach. Under the first phase, the workgroup met regularly to define the purpose of an emerging constituents investigation program, to review the lessons learned from past and present emerging constituents monitoring programs, to survey the technical capability of well-qualified commercial laboratories to analyze for emerging constituents, and to identify the potential regulatory issues that may arise as a result of collecting and publishing emerging constituent data. A Phase I report was completed and forwarded to the Regional Board in December 2008. Thereafter, under Phase II, the workgroup met monthly to develop a long-term characterization program for emerging constituents and to define requirements for the submittal of an annual report based on sampling conducted for specific emerging constituents in the Santa Ana region. The Phase II report was completed and submitted to the Regional Board for approval in December 2009.

As defined in the Phase II report, the workgroup designated the Santa Ana Watershed Project Authority (SAWPA) as the lead agency to prepare an annual emerging constituents report for submittal to the Regional Board based on sampling and laboratory analysis data submitted by the TASK FORCE AGENCIES and other cooperating agencies to SAWPA.

B. **The Purpose of the Task Force Agreement.** The purpose of this Task Force Agreement is to form a task force to oversee and conduct the necessary annual report for the Emerging Constituents Characterization program as defined in the SAWPA Phase II Emerging Constituents Workplan approved by the Regional Board on Dec. 10, 2009. The Task Force is proposed to consist of the TASK FORCE AGENCIES to direct the study and fund it on an equitable basis to be determined by the Task Force.

## II. COVENANTS

NOW, THEREFORE; in consideration of the foregoing recitals and mutual covenants contained herein, the TASK FORCE AGENCIES agree as follows:

1. Creation of a Task Force.

There is hereby created a "Task Force to Conduct an Emerging Constituents Characterization Program for the Santa Ana River Watershed" initially consisting of the TASK FORCE AGENCIES and other entities as more specifically provided for in paragraph 3 below.

2. Purpose of the Task Force.

The purpose of the Task Force is to provide oversight and supervision of the work that is described herein.

3. Membership and Organization.

a. Regular Members. Concurrent with the execution of this AGREEMENT, each of the TASK FORCE AGENCIES shall appoint one regular representative to the Task Force and one alternate representative to act in the absence of the regular representative. The representatives must be vested with the authority to act on behalf of the appointing TASK FORCE AGENCY, but only as provided for in this AGREEMENT. No actions by the TASK FORCE AGENCIES shall bind the TASK FORCE AGENCIES, except as explicitly provided for in this AGREEMENT. The identity of the appointed representatives shall be promptly communicated in writing to SAWPA. The representatives shall serve at the pleasure of the appointing TASK FORCE AGENCY and may be removed at any time, with or without cause; provided, however, that the TASK FORCE AGENCIES acknowledge and agree that the continuity of representation on the Task Force is important to the overall effectiveness of the Task Force, and the TASK FORCE AGENCIES further agree to ensure such continuity whenever possible.

b. Additional Agencies. The TASK FORCE AGENCIES acknowledge and agree that the effectiveness of the Task Force may be improved by the inclusion of other public agencies as additional TASK FORCE AGENCIES to the Task Force. Such public agencies may join the Task Force on such written terms and conditions as are acceptable to all TASK FORCE AGENCIES, including, but not limited to, agreed-upon cash contributions for past, present, and/or future work, of the Task Force. The inclusion of such public agencies as additional TASK FORCE AGENCIES to the Task Force shall be effected by a written amendment to this AGREEMENT signed by all TASK FORCE AGENCIES. Such additional TASK FORCE AGENCIES shall appoint their Task Force representatives and alternates as provided in Section 3.a. above or in said written amendment.

c. Advisory Members. The Task Force may, from time to time, seek the advice and counsel of regulatory or special interest agencies, which agencies may serve as Advisory Members to the Task Force. Such Advisory Members shall have no obligation to provide funding and have no voting privileges. The California Regional Water Quality Control Board, Santa Ana Region, is hereby appointed as an Advisory Member of the Task Force. Additional Advisory Members may be appointed by a majority vote of the Task Force representatives.

d. Committees. The Task Force may establish committees, consisting of members who shall be selected by, and serve at the pleasure of the Task Force.

e. Task Force Administrator. SAWPA, acting through its Planning Department staff, is hereby appointed as the Task Force Administrator for purposes of this Task Force Agreement. SAWPA shall have the following administrative responsibilities and shall be reimbursed for time expended on behalf of the Task Force at SAWPA's current rate for salary, overhead, burden (2009-10 rates shown in Exhibit "A"), and cost of materials, and including costs for:

- (1) Organizing and facilitating Task Force meetings;
- (2) Secretarial, clerical, and administrative services;
- (3) Management of Task Force funds and provide annual reports of Task Force assets and expenditures;
- (4) Hire Task Force-authorized consultants as permitted by the Task Force budget.

SAWPA, as the Task Force Administrator, will act as the contracting party for the benefit of the Task Force, for contracts with all Task Force consultants or contractors. SAWPA will not contract, direct, instruct, or guide such consultants or contractors on behalf of the Task Force, or use funds provided by the Task Force without approval of, or guidance from, a majority of the Task Force representatives in accordance with Sections 3.f(2), 5 and 6 of this AGREEMENT. SAWPA will provide project management for work performed by such consultants or contractors.

f. Meetings of the Task Force.

(1) Frequency and Location. The Task Force meetings shall be held at the office of SAWPA and will be scheduled based on the consensus of the majority of the Task Force at mutually agreeable times and dates. Special meetings may be called at the request of the Task Force Administrator or by a majority of the Task Force representatives. All meetings of the Task Force or its committees shall be noticed and conducted in compliance with the Ralph M. Brown Act at Government Code, Section 54950 et seq.

(2) Quorum. A majority of the representatives of the Task Force shall constitute a quorum. Actions of the Task Force shall be passed and adopted upon the affirmative vote of a majority of the Task Force. Each TASK FORCE AGENCY shall have one vote. The Task Force may adopt such additional rules and regulations as may be required for the conduct of its affairs so long as such rules and regulations do not conflict with this AGREEMENT and applicable law.

(3) Meeting Notes. SAWPA shall keep, or cause to be kept, meeting notes of the Task Force meetings including handout materials used. Copies of the meetings and handouts shall be delivered to the Task Force representatives, each TASK FORCE AGENCY, and the Advisory Members.

4. Duties of the Task Force.

a. Emerging Constituents Sampling. An emerging constituent sampling effort will be conducted by the TASK FORCE and cooperating agencies at locations and frequency under the approved sampling and analysis plan and submit copies of all sampling documents (field notes and chain of custody forms) and laboratory reports to SAWPA.

b. Data Management and Reporting. SAWPA will input the data to the Santa Ana Watershed Database Management System (SAWDMS) database and prepare an annual report summarizing results of the emerging constituents characterization program. A draft copy of the emerging constituents report will be distributed for review and comment. SAWPA will convene a TASK FORCE meeting shortly thereafter to discuss suggested revisions to the draft document. The final report will be submitted to the Regional Board, on behalf of the stakeholders, by December 31st of each year. The annual report will include a detailed description of the chemical analytes, sampling locations, sampling dates and protocols, analytical methods, QA/QC procedures and relevant results. Where appropriate, the report also shall include any recommended changes to future emerging constituent sampling efforts (including revised analytes or sampling locations). The report also will describe the toxicological relevance of the measured emerging constituent concentrations.

c. Communications. To facilitate public understanding of the new information, an Emerging Constituents Communication plan will be developed describing challenges and concerns, strategies and tactics, immediate and future tasks, messaging and talking points.

d. Termination of Projects or Studies. The TASK FORCE AGENCIES hereby agree that the Task Force shall have the discretion to terminate its projects or studies in the event a consensus of the TASK FORCE AGENCIES cannot be maintained during the course of the Task Force projects or studies. In the event a project or study is terminated, any funds previously budgeted for the project or study shall be returned to the TASK FORCE AGENCIES who furnished such funds, except as otherwise provided in Section 7 herein.

5. Budgets.

On or before February 1st of each year, SAWPA will prepare and submit a draft Task Force budget for the next fiscal year to the Task Force and TASK FORCE AGENCIES. The proposed budget shall include all anticipated costs and fees for the scope(s) of work developed by the Task Force for the next fiscal year. Costs shall include costs and fees for any consultants or contractors to be hired by SAWPA to complete the anticipated scopes of work, any equipment or materials to be purchased, and any other direct costs. SAWPA shall include as a separate item in such proposed budgets costs of SAWPA administrative services. The proposed budget shall include a detailed description of all work to be accomplished with the budget. The budgets shall also set forth the funds to be deposited with SAWPA consistent with the budgeted costs and fees for that fiscal year. Each TASK FORCE AGENCY shall approve in advance on or before March 1st of each year, its pro-rata share of the Task Force proposed budget for the next fiscal year. The TASK FORCE AGENCY shall be asked to pay its pro-rata share at the commencement of the next fiscal year. The pro-rata share of such costs and fees for each TASK FORCE AGENCY will be as described in EXHIBIT "B", attached hereto and made a part of this AGREEMENT. Said EXHIBIT "B" shall be renewed each fiscal year to reflect the final budget and the participating TASK FORCE AGENCIES of that fiscal year, and any other factor that may affect the pro-rata share of such costs and fees for each TASK FORCE AGENCY for that fiscal year. EXHIBIT "B" includes by its attachment the funding sources for Fiscal Year (July 1<sup>st</sup> to June 30<sup>th</sup>) 2010-2011, and a budget for that fiscal year shall be adopted by the Task Force and TASK FORCE AGENCIES after this AGREEMENT has been fully executed. In the event that any TASK FORCE AGENCY withdraws from the Task Force, the budget then in effect shall be adjusted in order to provide for any funding shortfall caused by such withdrawal.

6. Contracting.

Upon Task Force approval, SAWPA shall hire consultants and contractors, as necessary, to complete the scope of work that has been funded by TASK FORCE AGENCIES each fiscal year. SAWPA shall not obligate funds that have not been delivered to SAWPA by the TASK FORCE AGENCIES.

7. Duration of Agreement.

This AGREEMENT shall not terminate except by mutual agreement of a majority of the TASK FORCE AGENCIES provided that all debts and liabilities of the Task Force are satisfied. Notwithstanding the foregoing, each TASK FORCE AGENCY reserves the right to terminate its participation at any time, upon sixty (60) days' written notice to the Task Force. Task Force projects and studies already undertaken on behalf of TASK FORCE AGENCIES at the time of withdrawal by a TASK FORCE AGENCY shall be fully funded by the TASK FORCE AGENCIES, including the withdrawing TASK FORCE AGENCY, at the time projects or studies are approved by the Task Force for implementation. A withdrawing TASK FORCE AGENCY shall not be entitled to any refund for programs or studies already underway. Any refund of surplus funds due to the withdrawing TASK FORCE AGENCY shall be paid sixty (60) days after the completion of tasks, projects and studies undertaken or in progress.

8. Ownership of Documents.

All work or deliverables produced, including originals prepared by anyone in connection with, or pertaining to, the work of the Task Force, shall become the property of the TASK FORCE AGENCIES, individually and collectively. Provided, however, that any withdrawn TASK FORCE AGENCY shall only be entitled to such work or deliverables if the withdrawn TASK FORCE AGENCY has fully contributed funds for such work or deliverables.

9. Assignment.

No right, duty or obligation of whatever kind or nature created herein shall be assigned without the prior written consent of all TASK FORCE AGENCIES.

10. Effective Date.

This Task Force Agreement shall become effective when it has been executed by a majority of the TASK FORCE AGENCIES pursuant to necessary authorization by each TASK FORCE AGENCY.

11. Counterparts.

This AGREEMENT may be executed in original counterparts, which together shall constitute a single agreement.

12. Independent Contractor Status.

This AGREEMENT is not intended and shall not be construed so as to create the relationship of agent, servant, employee, partnership, joint venture or association, as between the TASK FORCE AGENCIES.

13. Waiver of Rights.

The failure by the TASK FORCE AGENCIES or SAWPA to insist upon strict performance of any of the terms, covenants or conditions of this AGREEMENT shall not be deemed a waiver of any right or remedy that TASK FORCE AGENCIES and SAWPA may have, and shall not be deemed a waiver of the right to require strict performance of all the terms, covenants and conditions of this AGREEMENT thereafter, nor a waiver of any remedy for the subsequent breach or default of any term, covenant or condition of this AGREEMENT.

14. Severability.

If any part of this AGREEMENT is held, determined or adjudicated to be illegal, void, or unenforceable by a court of competent jurisdiction, the remainder of this AGREEMENT shall be given effect to the fullest extent reasonably possible.

15. Amendment.

It is mutually understood and agreed that no addition to, alteration of, or variation of the terms of this AGREEMENT, nor any oral understanding or agreement not incorporated herein, shall be valid unless made in writing and signed and approved by all TASK FORCE AGENCIES and SAWPA.

16. Entire Agreement.

This document sets forth the entire Agreement between and among the TASK FORCE AGENCIES and SAWPA.

17. Availability of Funds.

The obligation of each TASK FORCE AGENCY is subject to the availability of funds appropriated by each TASK FORCE AGENCY for the purposes herein. Any obligation for the future payment of money beyond the current fiscal year is conditioned upon the governing body of each TASK FORCE AGENCY providing adequate appropriations in the adopted budgets for those subsequent fiscal years. This condition applies to, but is not limited to, the obligations of the TASK FORCE AGENCIES under Section 3.e (Task Force Administrator), and Section 5 (Budgets) of this AGREEMENT. Based on the financial constraints imposed by this Section 17, the TASK FORCE AGENCIES understand that SAWPA is under no duty to perform any services under this AGREEMENT until and unless the each TASK FORCE AGENCY has approved the fiscal year budget under Section 5, and has appropriated and deposited with SAWPA the necessary monies to fund the approved budget. In the event that one or more of the TASK FORCE AGENCIES fails to deposit its full share of the approved budget with SAWPA, the remaining TASK FORCE AGENCIES may, but shall not be required to, contribute additional funds in order to pay for the services contemplated by the budget. The TASK FORCE AGENCIES acknowledge that any failure by one or more of the TASK FORCE AGENCIES to appropriate and deposit monies with SAWPA to fund the budget will necessarily delay the



performance of the services by SAWPA contemplated by this AGREEMENT, and SAWPA shall not be held responsible or liable for any such delay or costs incurred from such a delay.

18. Indemnity and Insurance.

a. SAWPA shall require all consultants or contractors performing work or services for the Task Force to defend, indemnify and hold harmless SAWPA and each of the TASK FORCE AGENCIES from any and all claims, damages, lawsuits, fines, penalties, including attorneys' fees and costs, arising from or related to the works or services provided by such consultants or contractors. Such contractors or consultants also shall maintain the following insurances and keep certificates of such insurances on file with SAWPA, on behalf of the Task Force:

(1) **Workers Compensation Insurance.** A program of Workers Compensation insurance or a state approved self-insurance program shall be in an amount and form to meet all applicable requirements of the Labor Code of California, covering all persons and entities providing services on behalf of the consultant or contractor and all risks of such persons or entities under this AGREEMENT.

(2) **Comprehensive General and Automobile Liability Insurance.** Comprehensive personal injury and property damage liability coverage shall include contractual coverage and automobile liability, if applicable, and including coverage for owned, hired and non-owned vehicles. The policy shall have a combined single limit for bodily injury and property damage of at least \$1,000,000.00. SAWPA and each TASK FORCE AGENCY shall be named as additional insureds on the policy providing such coverage, and any right of subrogation shall be waived.

(3) **Professional Liability Insurance.** Professional liability insurance shall include limits of at least \$1,000,000.00 per claim or occurrence, unless such coverage is waived by the Task Force representatives.

b. Nothing in this AGREEMENT is intended to create, nor shall anything herein be construed as creating, any rights in, benefits for or obligations to, any person or entity other than SAWPA and the TASK FORCE AGENCIES.

c. Each Party to this AGREEMENT shall, pursuant to Government Code sections 895 *et seq.* and other applicable law, indemnify and hold harmless the other parties to this AGREEMENT, and their respective directors, officers, employees and agents from and against all damages, liabilities, claims, actions, demands, costs and expenses (including, but not limited to, costs of investigations, lawsuits and any other proceedings whether in law or in equity, settlement costs, attorneys' fees and costs), and penalties or violations of any kind, which arise out of, result from, or are related to the activities undertaken pursuant to this AGREEMENT. Such rights shall include but are not limited to the right of contribution pursuant to Government Code sections 895.4 and 895.6.

d. The provisions of paragraph 18 shall survive the termination of this AGREEMENT.

19. Nondiscrimination.

SAWPA shall ensure that during the term of this AGREEMENT it and any consultant retained by it shall not discriminate on the grounds of race, religion, creed, color, national origin, ancestry, age, physical disability, mental disability, medical condition, including the medical condition of Acquired Immune Deficiency Syndrome (AIDS) or any other condition related thereto, marital status, sex, or sexual orientation, in the selection and retention of employees and subcontractors and the procurement of materials and equipment, except as provided in Section 12940 of the California Government Code, in the performance of this AGREEMENT and also shall comply with the applicable provisions of the Americans with Disabilities Act.

20. Warranty of Authority.

Each of the individuals executing this AGREEMENT represent and warrant that she or he has the legal power, right, and actual authority to bind their respective TASK FORCE AGENCIES to the terms and conditions of this AGREEMENT. Each individual executing this AGEEMENT further represents and warrants that the AGREEMENT has been approved by his or her respective TASK FORCE AGENCY'S governing board or appropriate authorizing entity.

21. Dispute Resolution.

Any dispute which may arise by and between the parties to this AGREEMENT shall first be submitted to non-binding mediation, conducted by a neutral, impartial mediation service that the parties mutually agree upon in writing.

IN WITNESS WHEREOF, SAWPA and the TASK FORCE AGENCIES have executed this AGREEMENT on the date set forth below.

**EASTERN MUNICIPAL WATER DISTRICT**

DATE \_\_\_\_\_ BY \_\_\_\_\_  
President

DATE \_\_\_\_\_ BY \_\_\_\_\_  
Secretary

**INLAND EMPIRE UTILITIES AGENCY**

DATE \_\_\_\_\_ BY \_\_\_\_\_  
President

DATE \_\_\_\_\_ BY \_\_\_\_\_  
Secretary

**ORANGE COUNTY WATER DISTRICT**

DATE \_\_\_\_\_ BY \_\_\_\_\_  
President

DATE \_\_\_\_\_ BY \_\_\_\_\_  
Secretary

**SAN BERNARDINO VALLEY MUNICIPAL WATER DISTRICT**

DATE \_\_\_\_\_

BY \_\_\_\_\_  
President

DATE \_\_\_\_\_

BY \_\_\_\_\_  
Secretary

**WESTERN MUNICIPAL WATER DISTRICT**

DATE \_\_\_\_\_

BY \_\_\_\_\_  
President

DATE \_\_\_\_\_

BY \_\_\_\_\_  
Secretary

**ELSINORE VALLEY MUNICIPAL WATER DISTRICT**

DATE \_\_\_\_\_

BY \_\_\_\_\_  
President

DATE \_\_\_\_\_

BY \_\_\_\_\_  
Secretary

**IRVINE RANCH WATER DISTRICT**

DATE \_\_\_\_\_

BY \_\_\_\_\_  
President

DATE \_\_\_\_\_

BY \_\_\_\_\_  
Secretary

JURUPA COMMUNITY SERVICES DISTRICT

DATE \_\_\_\_\_

BY \_\_\_\_\_  
President, Board of Directors

LEE LAKE WATER DISTRICT

DATE \_\_\_\_\_

BY \_\_\_\_\_  
President

DATE \_\_\_\_\_

BY \_\_\_\_\_  
Secretary

METROPOLITAN WATER DISTRICT OF SOUTHERN CALIFORNIA

DATE \_\_\_\_\_

BY \_\_\_\_\_  
President

DATE \_\_\_\_\_

BY \_\_\_\_\_  
Secretary

SAN GORGONIO PASS WATER AGENCY

DATE \_\_\_\_\_

BY \_\_\_\_\_  
Chair

DATE \_\_\_\_\_

BY \_\_\_\_\_  
Secretary-Treasurer

YUCAIPA VALLEY WATER DISTRICT

DATE \_\_\_\_\_

BY \_\_\_\_\_  
President, Board of Directors

**CITY OF BEAUMONT**

DATE \_\_\_\_\_

BY \_\_\_\_\_  
Mayor

DATE \_\_\_\_\_

BY \_\_\_\_\_  
City Clerk

**CITY OF CORONA**

DATE \_\_\_\_\_

BY \_\_\_\_\_  
Mayor

DATE \_\_\_\_\_

BY \_\_\_\_\_  
City Clerk

**CITY OF REDLANDS**

DATE \_\_\_\_\_

BY \_\_\_\_\_  
Mayor

DATE \_\_\_\_\_

BY \_\_\_\_\_  
City Clerk

**CITY OF RIALTO**

DATE \_\_\_\_\_

BY \_\_\_\_\_  
Mayor

DATE \_\_\_\_\_

BY \_\_\_\_\_  
City Clerk

**CITY OF RIVERSIDE**

DATE \_\_\_\_\_

BY \_\_\_\_\_  
Mayor

DATE \_\_\_\_\_

BY \_\_\_\_\_  
City Clerk

**CHINO BASIN WATERMASTER**

DATE \_\_\_\_\_

BY \_\_\_\_\_  
President

DATE \_\_\_\_\_

BY \_\_\_\_\_  
Secretary

**COLTON/SAN BERNARDINO REGIONAL TERTIARY TREATMENT  
AND WASTEWATER RECLAMATION AUTHORITY**

DATE \_\_\_\_\_

BY \_\_\_\_\_  
President

DATE \_\_\_\_\_

BY \_\_\_\_\_  
Secretary

**WESTERN RIVERSIDE COUNTY REGIONAL WASTEWATER  
AUTHORITY**

DATE \_\_\_\_\_

BY \_\_\_\_\_  
Chair

DATE \_\_\_\_\_

BY \_\_\_\_\_  
Secretary-Treasurer

**SANTA ANA WATERSHED PROJECT AUTHORITY**

DATE \_\_\_\_\_

BY \_\_\_\_\_  
Chair

DATE \_\_\_\_\_

BY \_\_\_\_\_  
Secretary-Treasurer

EXHIBIT A

Overhead and burden are included in all rates. Labor for SAWPA staff shall be billed at the rates in Table 1 below for FY 09-10. Rates will be adjusted annually based on SAWPA's annual budget. Materials purchased to provide administrative services that are not shown in Table 1 below shall be billed at direct cost with no additional fees or mark-ups.

<b>Table 1 SAWPA Rate Sheet</b>	
<b>Item</b>	<b>Rate</b>
Water Resources & Planning Manager	\$ 194.86/hour
Watershed Planner	\$ 147.06/hour
Sr. Administrative Assistant	\$ 92.08/hour
Administrative Assistant II	\$ 82.96/hour
Administrative Assistant I	\$ 60.49/hour
Senior Accounting Technician	\$ 82.96/hour
Automobile Travel	Federal mileage rate for automobile travel to meeting locations.
Out of Town travel (when air travel or overnight stay is required)	Direct cost of air travel plus direct cost of lodging and meals.

**EXHIBIT B  
TASK FORCE BUDGET**

**A. CONTRIBUTIONS**

1. Study Contributions. In order to participate in the activities of the Task Force, each TASK FORCE AGENCY shall appropriate and deliver to SAWPA its agreed upon share of the funding. The TASK FORCE AGENCIES specifically recognize that each TASK FORCE AGENCY's agreed-upon share is determined by that TASK FORCE AGENCY, who is the signatory to this AGREEMENT. Funding shall be provided by the TASK FORCE AGENCIES in accordance with the attachment to this Exhibit.
2. Funds appropriated by each TASK FORCE AGENCY to the activities of the Task Force shall be expended only for the purposes expressed in this AGREEMENT. Funds shall be deposited in a restricted, interest-bearing account for the benefit of the Task Force, administered by SAWPA. Funds shall be strictly accounted to each TASK FORCE AGENCY. Upon termination of the Agreement and the activities of the Task Force, any funds not used shall be returned to the TASK FORCE AGENCIES in proportion to their contribution as provided in the Agreement.
3. The compensation to be paid to consultant(s) hired by Task Force is subject to SAWPA's receipt of funds from the TASK FORCE AGENCIES. The consultant will be directed to limit its activities to ensure that the Consultant does not expend funds or provide services for which SAWPA has not yet collected funds from the TASK FORCE AGENCIES. SAWPA shall endeavor to obtain the funds needed to fully fund the scope of work.



*FY 10-11 Emerging Constituents Workgroup Budget Allocation*

<b>Projected Expenses</b>	SAWPA TF Admin & Contract Adm	\$30,000
	SAWPA EC Annual Sampling Report	\$27,500
	Risk Sciences - Sampling Report Update	<u>\$30,000</u>
		<b>\$87,500</b>

**Projected Revenue**

	<b>POTW &amp; Agmt Parties Share</b>	<b>Totals</b>
<i>1-18-08 Cooperative Agreement Parties</i>		
OCWD		In Kind
SGPWA	\$2,500	\$2,500
SBVMWD		<b>\$25,000</b>
<i>1-18-08 Cooperative Agmt Parties &amp; Permittees</i>		
WMWD		\$25,000
RIX JPA	\$2,500	\$2,500
EMWD	\$2,500	\$2,500
EVMWD	\$2,500	\$2,500
City of Corona	\$2,500	\$2,500
City of Riverside	\$2,500	\$2,500
<i>Other Permittees</i>		
WRCRWA		
IEUA	\$2,500	\$2,500
REDLANDS	\$2,500	\$2,500
RIALTO	\$2,500	\$2,500
YVWD	\$2,500	\$2,500
JCSD	\$2,500	\$2,500
LEE LAKE WD	\$2,500	\$2,500
BEAUMONT	\$2,500	\$2,500
CBWM	\$2,500	\$2,500
IRWD	<u>\$2,500</u>	<u>\$2,500</u>
	<b>\$37,500</b>	<b>\$87,500</b>
<i>Other Agency</i>		
MWDSC		In Kind

Footnotes:

Proposed Allocation: \$25,000 SBVMWD + \$25,000 WMWD + POTW & other Cooperative Agmt Parties except WRCRWA & OCWD  
 SBVMWD and WMWD's offered funding portions based on 1/12/09 ltr to SAWPA.  
 MWDSC's in-kind contribution as set forth in the Phase II EC Report attached hereto as Exhibit C and incorporated by reference or as subsequently agreed upon between MWDSC and other Task Force agencies.

**EXHIBIT C**

Attach Final Phase II Report of the Emerging Constituents Workgroup

THIS PAGE  
HAS  
INTENTIONALLY  
BEEN LEFT  
BLANK  
FOR PAGINATION



# CHINO BASIN WATERMASTER

## II. BUSINESS ITEM

### B. AMENDMENT NO. 1 TO AGREEMENT TO FORM A TASK FORCE

Consider Approval of Amendment No. 1 to Form a Task Force to Conduct a Basin Monitoring Program for Nitrogen and Total Dissolved Solids in the Santa Ana River Watershed (Basin Monitoring Program)





# CHINO BASIN WATERMASTER

9641 San Bernardino Road, Rancho Cucamonga, Ca 91730  
Tel: 909.484.3888 Fax: 909.484.3890 www.cbwm.org

**KENNETH R. MANNING**  
Chief Executive Officer

## STAFF REPORT

**DATE:** April 15, 2010  
**TO:** Committee Members  
**SUBJECT:** Amendment No. 1 to Form a Task Force to Conduct a Basin Monitoring Program for Nitrogen and Total Dissolved Solids in the Santa Ana River Watershed (Basin Monitoring Program)

### SUMMARY

**Recommendation** – No Action is Required for April. Staff Will Provide Further Report and Seek Guidance from the Watermaster Board

**Financial Impact** - Annual budget is prepared by the Task Force and its pro-rata share of such costs and fees are shared among the TASK FORCE AGENCIES. The budget proposed for the fiscal year 2010/11 is \$433,449 and the Watermaster's share is \$25,778.

### BACKGROUND

In December 1995, the Nitrogen TDS Task Force, consisting of 22 water resource agencies in the Santa Ana Watershed including Watermaster, was formed to oversee a study to evaluate the impacts of Total Inorganic Nitrogen (TIN) and Total Dissolved Solids (TDS) on water resources in the Santa Ana River Watershed. The study was completed in mid 2003. On January 22, 2004, the Santa Ana Regional Water Quality Control Board (RWQCB) incorporated the results of the Nitrogen TDS Task Force study into a Basin Plan Amendment for Nitrogen and TDS and adopted the Basin Plan Amendment. The Task Force Agencies were named in that Basin Plan Amendment as responsible for conduct in various monitoring programs and analyses to support the results defined in the Basin Plan Amendment.

Watermaster Board signed the AGREEMENT to Form a Task Force to Conduct a Basin Monitoring Program for Nitrogen and Total Dissolved Solids in the Santa Ana River Watershed (Basin Monitoring Program) in August 2004. Because of the need to perform additional work, the Amendment to the original AGREEMENT is required. The modifications of the language include:

1. The purpose of the Task Force to include performing other related cooperative studies as agreed to by the Task Force AGENCIES; and
2. Conduct Santa Ana River (SAR) Wasteload Allocations and other related studies by the TASK FORCE AGENCIES.

**Actions:**

- April 8, 2010 Appropriative Pool – Discussion Only
- April 8, 2010 Non-Agricultural Pool – Discussion Only
- April 8, 2010 Agricultural Pool – Discussion Only
- April 15, 2010 Advisory Committee –
- April 22, 2010 Watermaster Board –

AMENDMENT NO. 1  
TO  
AGREEMENT TO FORM A TASK FORCE  
TO CONDUCT A  
BASIN MONITORING PROGRAM FOR  
NITROGEN AND TOTAL DISSOLVED SOLIDS  
IN THE SANTA ANA RIVER WATERSHED  
(BASIN MONITORING PROGRAM)

Pursuant to Paragraph II.15 of that certain AGREEMENT entitled, "Agreement to Form a Task Force to Conduct a Basin Monitoring Program for Nitrogen and Total Dissolved Solids in the Santa Ana River Watershed", dated August 10, 2004, the TASK FORCE AGENCIES hereby agree to make the following changes:

1. Under I. Recitals B. The Purpose of the Task Force Agreement shall be revised to read as follows:

The purpose of this AGREEMENT is to form a task force to oversee and conduct the studies for the Basin Monitoring Program as described in the RWQCB's Basin Plan Amendment **and perform other related cooperative studies as agreed to by the TASK FORCE AGENCIES.** The Task Force is proposed to consist of the TASK FORCE AGENCIES to direct the study and fund it on an equitable basis to be determined by the TASK FORCE AGENCIES.

2. The TASK FORCE AGENCIES hereby amend Paragraph II. 4 (Duties of the Task Force) of the Task Force Agreement to include the following tasks to be funded by the TASK FORCE AGENCIES and authorize the Task Force Administrator to conduct such tasks.

d. Conduct Santa Ana River (SAR) Wasteload Allocations and other related studies

Hire a consultant to perform updates to the SAR Wasteload Allocation Report, work with the RWQCB staff and TASK FORCE AGENCIES on appropriate model runs to be used for new RWQCB Basin Plan Amendments for the SAR Wasteload Allocation and provide appropriate input for new Basin Plan Amendment language as needed. Additional studies may also be conducted to support the purposes of the TASK FORCE AGENCIES as directed by a consensus of the TASK FORCE AGENCIES.

Except as otherwise expressly amended herein, all of the terms, conditions, and provisions of the AGREEMENT shall continue in full force and effect.

IN WITNESS WHEREOF, the parties hereto have executed this Amendment on the dates set forth below.

**CITY OF BEAUMONT**

DATE \_\_\_\_\_

BY \_\_\_\_\_  
Mayor

DATE \_\_\_\_\_

BY \_\_\_\_\_  
City Clerk

**CHINO BASIN WATERMASTER**

DATE \_\_\_\_\_

BY \_\_\_\_\_  
President

DATE \_\_\_\_\_

BY \_\_\_\_\_  
Secretary

**COLTON/SAN BERNARDINO REGIONAL  
TERTIARY TREATMENT AND WASTEWATER  
RECLAMATION AUTHORITY**

DATE \_\_\_\_\_

BY \_\_\_\_\_  
President

DATE \_\_\_\_\_

BY \_\_\_\_\_  
Secretary



**CITY OF CORONA**

DATE \_\_\_\_\_

BY \_\_\_\_\_  
DWP General Manager

DATE \_\_\_\_\_

BY \_\_\_\_\_  
City Clerk

**EASTERN MUNICIPAL WATER DISTRICT**

DATE \_\_\_\_\_

BY \_\_\_\_\_  
President

DATE \_\_\_\_\_

BY \_\_\_\_\_  
Secretary

**ELSINORE VALLEY MUNICIPAL WATER DISTRICT**

DATE \_\_\_\_\_

BY \_\_\_\_\_  
President

DATE \_\_\_\_\_

BY \_\_\_\_\_  
Secretary

**INLAND EMPIRE UTILITIES AGENCY**

DATE \_\_\_\_\_

BY \_\_\_\_\_  
President

DATE \_\_\_\_\_

BY \_\_\_\_\_  
Secretary

**IRVINE RANCH WATER DISTRICT**

DATE \_\_\_\_\_

BY \_\_\_\_\_  
President

DATE \_\_\_\_\_

BY \_\_\_\_\_  
Secretary

**JURUPA COMMUNITY SERVICES DISTRICT**

DATE \_\_\_\_\_

BY \_\_\_\_\_  
President, Board of Directors

**ORANGE COUNTY WATER DISTRICT**

DATE \_\_\_\_\_

BY \_\_\_\_\_  
President

DATE \_\_\_\_\_

BY \_\_\_\_\_  
Secretary

**CITY OF RIALTO**

DATE \_\_\_\_\_

BY \_\_\_\_\_  
Mayor

DATE \_\_\_\_\_

BY \_\_\_\_\_  
City Clerk

**CITY OF RIVERSIDE**

DATE \_\_\_\_\_

BY \_\_\_\_\_  
Mayor

DATE \_\_\_\_\_

BY \_\_\_\_\_  
City Clerk

**CITY OF REDLANDS**

DATE \_\_\_\_\_

BY \_\_\_\_\_  
Mayor

DATE \_\_\_\_\_

BY \_\_\_\_\_  
City Clerk

**SAN TIMOTEO WATERSHED MANAGEMENT  
AUTHORITY**

DATE \_\_\_\_\_

BY \_\_\_\_\_  
President

DATE \_\_\_\_\_

BY \_\_\_\_\_  
Secretary

**SANTA ANA WATERSHED PROJECT AUTHORITY**

DATE \_\_\_\_\_

BY \_\_\_\_\_  
Chair

DATE \_\_\_\_\_

BY \_\_\_\_\_  
Secretary-Treasurer

**WESTERN RIVERSIDE COUNTY REGIONAL  
WASTEWATER AUTHORITY**

DATE \_\_\_\_\_

BY \_\_\_\_\_  
Chair

DATE \_\_\_\_\_

BY \_\_\_\_\_  
Secretary-Treasurer

**YUCAIPA VALLEY WATER DISTRICT**

DATE \_\_\_\_\_

BY \_\_\_\_\_  
President, Board of Directors



# CHINO BASIN WATERMASTER

## III. REPORTS / UPDATES

### E. INLAND EMPIRE UTILITIES AGENCY

1. Recycled Water Recharge Program Update
7. State and Federal Legislative Reports
8. Community Outreach/Public Relations Report
9. Peace II PEIR Schedule



**CHINO BASIN WATERMASTER**

**ADVISORY COMMITTEE**

**April 15, 2010**

**AGENDA**

**INTERAGENCY WATER MANAGERS' REPORT**

**Chino Basin Watermaster**

**9641 San Bernardino Road**

**Rancho Cucamonga, CA 91730**

---

**Discussion Items:**

- Recycled Water Groundwater Recharge Program Update (powerpoint/oral)
- MWD Water Rates and Budget Update – oral
- State Water Project Allocation Update – oral
- DYY Third Call Year
- WSAP Second Allocation Year

**Written Items:**

- Monthly Water Use Report (handout)
- State and Federal Legislative Reports
- Community Outreach/Public Relations Report
- Peace II SEIR Schedule

THIS PAGE  
HAS  
INTENTIONALLY  
BEEN LEFT  
BLANK  
FOR PAGINATION

**Inland Empire Utilities Agency**  
**Recycled Water Groundwater**  
**Recharge Program Update**

**Patrick Shields**  
**Executive Manager of Operations**



# IEUA Water Recycling Facilities

- Four Water Recycling Facilities
  - Regional Plant No. 1 – Ontario
  - Regional Plant No. 4 – Rancho Cucamonga
  - Regional Plant No. 5 – Chino
  - Carbon Canyon Water Recycling Facility – Chino
- Influent Flow Levels
- Water Quality
- Recycled Water Demand

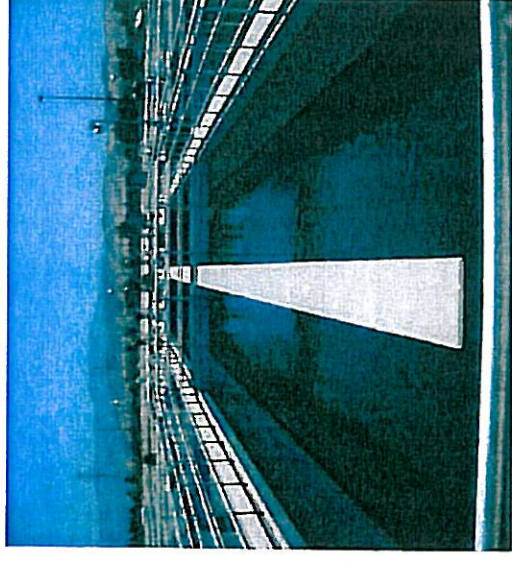

**Design Capacity:**  
**84.4 Million Gallons per Day**  
**Actual Average Daily Flow:**  
**58 Million Gallons per Day**

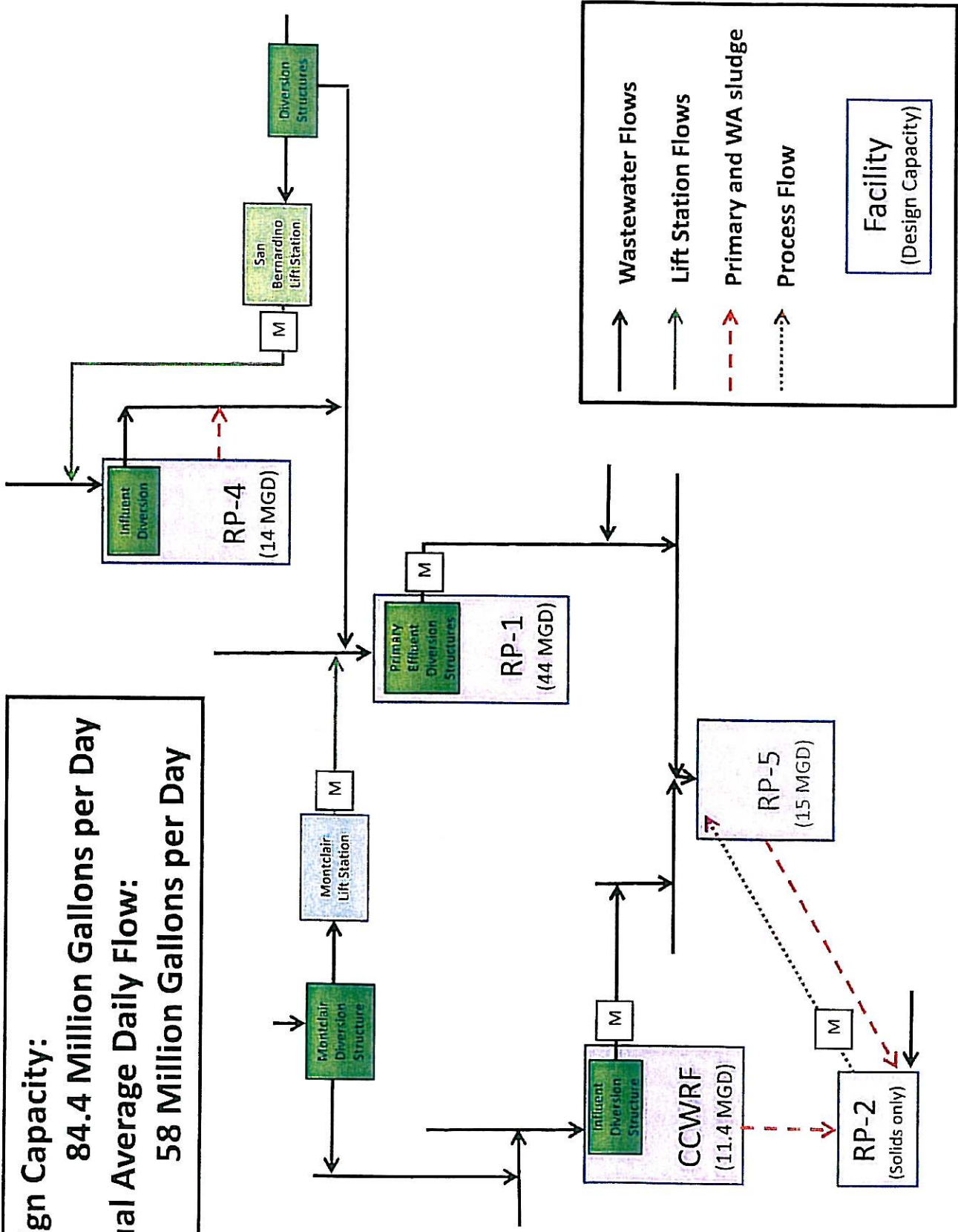

# IEUA Recycled Water Production Cycle

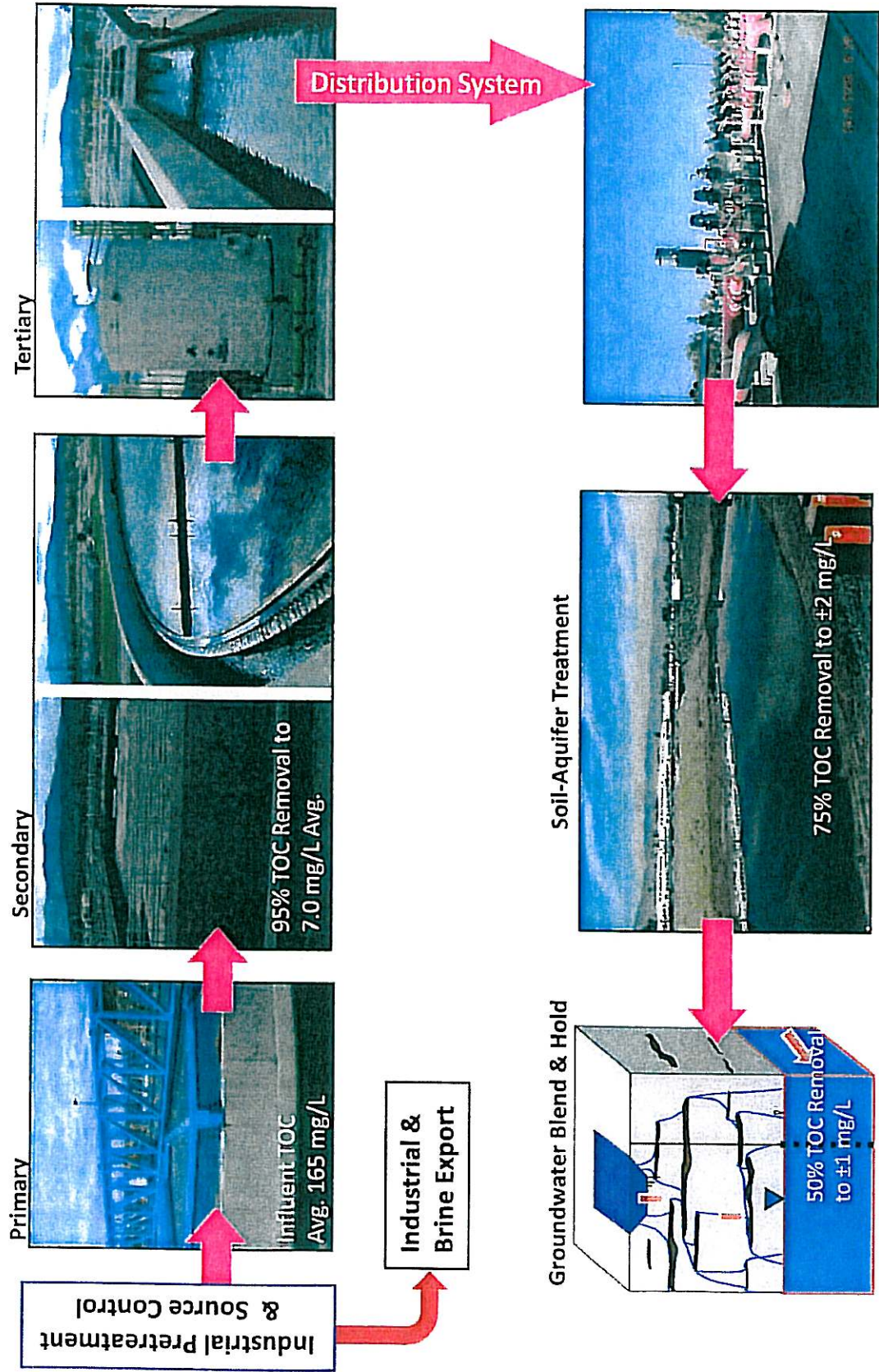

# Exceptional Recycled Water Quality

- Pre-Treatment Program
  - Manages Significant Industrial Users (SIU)
  - No Drugs Down the Drain Program
  - Industrial & Brine Export to NRWS (reduced salinity)
  - Rebates on residential water softeners/future ban on new water softeners
- Longstanding Treatment Facility Performance
  - Outstanding NPDES & T-22 Compliance Record
    - 100% Compliant for 2008
  - Exceptional Nitrogen and TOC Removal
  - No Issues with Emerging Constituents of Concern

# Groundwater Recharge

- Recharge Sites
  - 14 DPH/RWQCB Permitted for RW
- Sources of Water
  - Stormwater & Local Runoff
  - Imported Water (MWD)
  - Recycled Water
- Natural Soil Aquifer Treatment (SAT) equivalent to MF/RO advanced treatment
- Confidence of Regulators/Independent Expert Panel Review
- Recharge Basin Operations & Maintenance (O&M)



# Chronology of Recycled Water Recharge

- CBWM adopted Recharge Master Plan (2002)
- IEUA Certified Program EIR for Recycled Water Master Plan (2002)
- CBWM Approved Article X permit application for recharge of up to 30,000 AF recycled water (June 2002)
- DPH/RWQCB Permit Phase I (2005)
- DPH/RWQCB Permit Phase II (2007)
- Additional Permit Conditions (2009) based on operational performance and exceptional quality

# Permitted Recycled Water Recharge Basins

Recharge Facility	Permitted for RW GWR	RW GWR Initiated
<b>Pre-CBFIP</b>		
Ely Basins	Yes	Sep 1999
<b>Phase I Recharge Project Basins</b>		
Banana Basin	Yes	Jul 2005
Declerz Basin	Yes	no pipeline
Etiwanda Conservation Ponds	Yes	no pipeline
Hickory Basin	Yes	Sep 2005
Jurupa Basin 3	No	
RP3 Basins	Yes	Jun 2009
Turner Basin Nos. 1 & 2	Yes	Jul 2006
Turner Basin Nos. 3 & 4	Yes	Jul 2006
<b>Phase II Recharge Project Basins</b>		
7th & 8th Street Basins	Yes	Sep 2007
Etiwanda Spreading Basins	Yes	no pipeline
Lower Day Basin	Yes	no pipeline
Brooks Street Basin	Yes	Aug 2008
College Heights Basins	No	
Montclair Basins Nos. 1-4	No	
Upland Basin	No	
San Sevaine Nos. 1 through 5	Yes	Summer 2010
Victoria Basin	Yes	Summer 2010

Order R8-2005-0033 (Phase I)

Order R8-2007-0039 (Phase II)





# Recycled Water Contribution

- Water Quality Based
  - Recycled Water Contribution (RWC)
  - Recycled Water Blended with Diluent Water
- Natural Soil Aquifer Treatment
  - Further Reduction of TN and TOC
  - Lysimeter & Well Monitoring

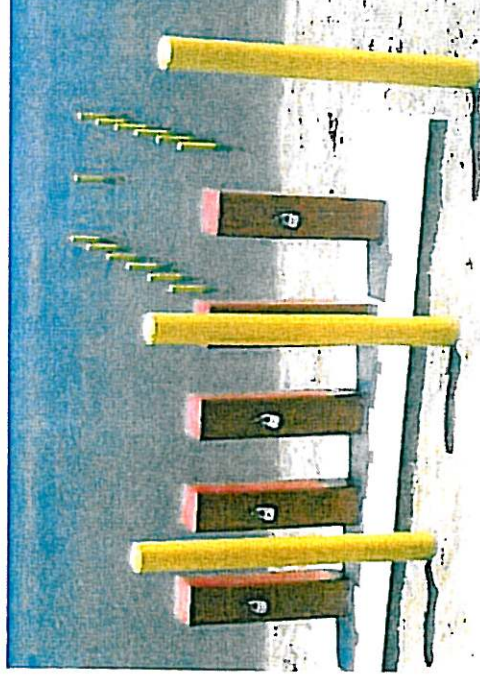

# Recent Permit Approvals (2009)

- Reliable & Demonstrated Compliance
  - 100% Compliance Record Since Start-Up
- Regulator Support of Permitting Modifications
  - DPH Recommendation to RWQCB (8/24/09)
    - 120-Month RWC Averaging Period
    - Allow Underflow to be Counted as Diluent Water
  - RWQCB Approval of Order R8-2009-57 (10/23/09)
    - Meets Equivalent Public Health Protection
    - Required Expert Panel

# Expert Panel

- **NWRI Convened Expert Panel**
  - James Crook, Ph.D., P.E., Environmental Engineering Consultant
  - Richard Bull, Ph.D., MoBull Consulting (former EPA public health expert)
  - Jean-François Debroux, Ph.D., Kennedy/Jenks Consultants
  - Jörg Drewes, Ph.D., Colorado School of Mines
  - Peter Fox, Ph.D., Arizona State University
  - Dennis Williams, Ph.D., P.G., CHG, GEOSCIENCE
- **2-Day Panel Workshop (February 2010)**
  - CBWM and IEUA provided history and operational data of recycled water recharge implementation to date
- **Final Report (April 2010)**



August 24, 2009

Mr. Gerald J. Thibeault  
Executive Officer  
California Regional Water Quality Control Board  
Santa Ana Region  
3737 Main St., Suite 500  
Riverside, CA 92501-3339

Dear Mr. Thibeault:

**INLAND EMPIRE UTILITIES AGENCY – REQUEST TO EXTEND RECYCLED  
WATER CONTRIBUTION COMPLIANCE PERIOD FOR CHINO BASIN**

Inland Empire Utilities Agency (IEUA) submitted a letter dated March 23, 2009, and a supplemental report dated July 2, 2009, requesting a change in the Recycled Water Contribution (RWC) averaging period for the Chino Basin Recycled Water Ground Water Recharge Program. IEUA is requesting that the current 60-month averaging period be changed to a 120-month averaging period to address the current water supply shortage of imported water from the State Water Project needed as diluent water in IEUA's groundwater recharge basins.

In a May 14, 2009, letter to IEUA, the California Department of Public Health (CDPH) outlined two primary areas in which additional information was needed to complete our review of the proposal: (1) evidence that an equivalent level of public health protection would be provided while operating under the proposed extended averaging period, and (2) a detailed contingency plan.

Equivalent Public Health Protection

Given the basin-specific nature of each recharge basin's soil aquifer treatment effectiveness and respective maximum RWC, we asked IEUA to consider the total organic carbon (TOC) loading at each basin that would occur under an extended averaging period. The purpose of determining the TOC loading was to further evaluate whether the proposal could maintain an equivalent level of public health protection as that provided under the current 60-month averaging period.

The additional documentation provided by IEUA indicates that the mass TOC loading to a recharge basin is independent of the RWC averaging period length if the TOC reduction achieved with soil aquifer treatment remains compliant with the maximum TOC limit, as calculated by CDPH's formula in the draft Groundwater Recharge Reuse Regulations (Section 60320.045, Title 22 CCR) using the maximum RWC.

IEUA has previously developed individual recycled water management plans for each recharge basin to monitor RWC, and recycled water and diluent water volumes. To be approved to operate at an extended RWC averaging period, IEUA will need to update the individual recycled water management plans for each of the basins. The plans must indicate the steps IEUA will take to ensure compliance with the maximum TOC limit for each basin, based on each basin's maximum RWC.

#### Contingency Plan

CDPH requested that IEUA provide a detailed contingency plan that would address the possibility of failure to meet the TOC limit under the proposed extended averaging period. Specifically, we requested a plan that presents definitive plans for treatment optimization, future additional advanced treatment, or other means of reducing organics in the recycled water used for recharging the basins if IEUA were to be unable to meet the running average RWC during the proposed extended averaging period. In light of the documentation presented regarding equivalent public health protection, as discussed above, CDPH believes there is no longer a need for a detailed and definitive contingency plan.

#### Additional Developments

IEUA has recently contracted with the National Water Research Institute (NWRI) to form an independent panel to monitor, evaluate, and report on IEUA's current groundwater recharge projects and on any possible implications that may result from extending the current 60-month averaging period for recycled water contribution. CDPH supports IEUA's reaching out to NWRI and we look forward to reviewing NWRI's report.

CDPH notes that the Chino Basin is a large groundwater aquifer and that depth to groundwater can be up to 250-300 feet; however, the quantity of the underflow in the basin has not been utilized in the calculations for diluent water by IEUA. Although CDPH's draft recharge reuse regulations state that the quantity of diluent water must be accurately determined to receive credit for dilution, CDPH may consider crediting a *fraction* of the flow as diluent water, which would be dependent on the accuracy of the method used to measure the flow, its distribution, and the ability to meet the other diluent water criteria in the draft regulation. Therefore, IEUA may find it beneficial to quantify the underflow when calculating RWCs for compliance; especially during an extended RWC averaging period.

#### Conclusion

CDPH recommends that the Santa Ana Regional Water Quality Control Board grant approval, through the proper permitting process, for IEUA to operate its groundwater

recharge facilities utilizing an extended RWC compliance period beyond the current 60-month period but not to exceed 120 months, subject to the following:

1. IEUA shall continue to implement and follow their Recycled Water Contribution Management Plan. For the purpose of the diluent water projections, implementation of a weighted averaging should be considered when it is known that imported water supplies will not be available for purposes of recharging the aquifer.
2. IEUA shall update the basin-specific recycled water management plans annually to reflect the estimated diluent water and recycled water contributions for the upcoming year. The plans must indicate the steps IEUA will take to ensure compliance with the maximum RWC and TOC limits for each basin.
3. IEUA shall maintain the recycled water contribution (RWC) volume based percentages as established and approved by CDPH in each of the basin start up plans. IEUA shall report any changes to an individual basin's soil aquifer treatment efficacy and the resulting RWC. The current basins having initiated recharge using recycled water together with the approved RWC limit are as follows:

<u>Basin</u>	<u>RWC</u>
Hickory	36%
Banana	36%
Ely	29%
Turner 1-2	25%
Turner 3 & 4	45%
8 <sup>th</sup> Street	TBD (pending flow cell data)
Brooks	TBD (Start-Up Plan review needed)

4. IEUA shall maintain an ongoing assessment of the individual basin Soil Aquifer Treatment (SAT) to ensure that TOC removals are consistent with the removals used to determine the initial RWC volume-based percentages as demonstrated in the basin specific Start-Up Reports.
5. IEUA shall suspend recycled water deliveries to the basins approved for recharge upon reaching the Recycled Water Contribution limit on or after month 96 of the 120 month period. Prior to resuming recycled water deliveries, IEUA shall prepare and submit a plan to achieve compliance with the Recycled Water Contribution Limits for review and approval.
6. IEUA has proposed the establishment of a scientific peer review panel. The panel should meet and provide a written report within 18 months from issuance of this letter regarding the items outlined in the scope of work. A panel member experienced in the engineering, design, and operation of SAT systems, in addition to a research-oriented expert in the SAT field, should be included on the panel.

Mr. Gerald J. Thibeault

Page 4

August 24, 2009

If you have any questions concerning this letter, please contact me at (916) 449-5577.

Sincerely,

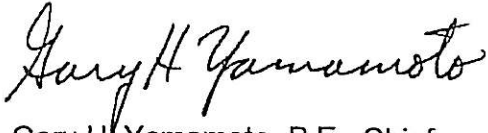
A handwritten signature in cursive script that reads "Gary H. Yamamoto".

Gary H. Yamamoto, P.E., Chief  
Division of Drinking Water  
and Environmental Management

cc: Patrick Sheilds  
Richard Atwater  
Inland Empire Utilities Agency  
P.O. Box 9020  
Chino Hills, CA 91709

Kenneth R. Manning  
Chino Basin Watermaster  
9641 San Bernardino Road  
Rancho Cucamonga, CA 91730

Mr. Gerald J. Thibeault  
Page 5  
August 24, 2009

bcc: Gary Yamamoto  
Steve Woods  
Leah Walker  
Mark Bartson  
Cindy Forbes  
Heather Collins  
Sean McCarthy  
Brian Bernados  
Jeff Stone  
Kurt Souza  
Bob Hultquist  
Dave Spath  
Mike McKibben



THIS PAGE  
HAS  
INTENTIONALLY  
BEEN LEFT  
BLANK  
FOR PAGINATION



California Regional Water Quality Control Board  
Santa Ana Region



Linda S. Adams  
Secretary for  
Environmental Protection

3737 Main Street, Suite 500, Riverside, California 92501-3348  
Phone (951) 782-4130 • FAX (951) 781-6288 • TDD (951) 782-3221  
[www.waterboards.ca.gov/santaana](http://www.waterboards.ca.gov/santaana)

Arnold  
Schwarzenegger  
Governor

October 30, 2009

Patrick Sheilds, Executive Manager of Operations [psheilds@ieua.org](mailto:psheilds@ieua.org)  
Inland Empire Utilities Agency  
6063 Kimball Avenue  
Chino, CA 91708

**TRANSMITTAL OF ADOPTED ORDER NO. R8-2009-0057**

At the regular Board Meeting of October 23, 2009, the Regional Board adopted Order No. R8-2009-0057, amending Order No. R8-2007-0039, Water Recycling Requirements for the Inland Empire Utilities Agency and Chino Basin Watermaster Chino Basin Recycled Water Groundwater Recharge Program Phase I and Phase II projects, San Bernardino County. A certified copy is enclosed for your records.

Sincerely,

Felipa Garrillo  
Executive Assistant

Enclosure: Adopted Order No. R8-2009-0057

cc via e-mail: SWRCB, DWQ--Phil Isorena [pisorena@waterboards.ca.gov](mailto:pisorena@waterboards.ca.gov)  
US EPA, Permits Issuance (WTR-5)--Doug Eberhardt [Eberhardt.Doug@epamail.epa.gov](mailto:Eberhardt.Doug@epamail.epa.gov)  
Tetra Tech - Lee Solomon (via email).  
Jae Kim - [jae.kim@tetrattech-ffx.com](mailto:jae.kim@tetrattech-ffx.com)  
Ahyung Kim- [ahyung.kim@tetrattech-ffx.com](mailto:ahyung.kim@tetrattech-ffx.com)

*California Environmental Protection Agency*



Recycled Paper

California Regional Water Quality Control Board  
Santa Ana Region

Order No. R8-2009-0057  
Amending Order No. R8-2007-0039,  
Water Recycling Requirements  
for

Inland Empire Utilities Agency and Chino Basin Watermaster  
Chino Basin Recycled Water Groundwater Recharge Program  
Phase I and Phase II Projects  
San Bernardino County

The California Regional Water Quality Control Board, Santa Ana Region (hereinafter, Regional Board), finds that:

1. On June 29, 2007, the Regional Board adopted Order No. R8-2007-0039 prescribing Water Recycling Requirements for the Inland Empire Utilities Agency (IEUA) and Chino Basin Watermaster (CBWM) Chino Basin Recycled Water Groundwater Recharge Program, Phase I and Phase II Projects. The Order authorizes the use of recycled water generated from IEUA's Regional Water Recycling Plants No. 1 and 4, for groundwater recharge via spreading in seven Phase I and six Phase II recharge basin sites located within the Chino North Groundwater Management Zone.
2. Order No. R8-2007-0039 allows IEUA and CBWM to apply a 60-month averaging period to comply with the approved maximum average recycled water contribution (RWC) and total organic carbon (TOC) limits for each recharge basin. The maximum average RWC and TOC limits are determined through the Start-Up Period and approved by the California Department of Public Health (CDPH) and the Regional Board. Also, the maximum average RWC and TOC limits for each basin can be increased upon approval by CDPH and the Regional Board after the first year following the Start-Up Period.
3. IEUA submitted a letter dated March 23, 2009 and a supplemental report dated July 2, 2009, to CDPH requesting a change in the RWC averaging period for the Chino Basin Recycled Water Groundwater Recharge Program. IEUA requested that the 60-month averaging period be changed to a 120-month averaging period to address the water supply shortage of imported water from State Water Project needed as diluent water in the groundwater recharge basins, while providing an equivalent level of public health protection.
4. In June 2009, IEUA and CBWM completed an evaluation of the total dissolved solids and nitrate projections for Chino North Management Zone showing that a change from a 60-month to a 120-month RWC averaging period will have a negligible impact on the Chino North Groundwater Management Zone's maximum benefit based total dissolved solids and total inorganic nitrogen water quality objectives.

5. In a letter dated August 24, 2009, CDPH determined that based on the information submitted by IEUA a 120-month averaging period provides an equivalent level of public health protection as the 60-month averaging period. Therefore, CDPH recommended to the Regional Board the approval of IEUA's request to operate its recycled water groundwater recharge program utilizing an extended RWC compliance period beyond the current 60-month period but not to exceed 120 months.
6. On August 31, 2009, IEUA and CBWM requested that Order No. R8-2007-0039 be amended in accordance with the recommendations forwarder to the Regional Board by CDPH in their letter dated August 24, 2009.
7. It is appropriate to amend Order No. R8-2007-0039 to incorporate the recommendations forwarder to the Regional Board by CDPH in their letter dated August 24, 2009.
8. In compliance with the California Environmental Quality Act (Public Resources Code Section 21000 et seq.), IEUA and CBWM prepared and certified an Environmental Impact Report for Phase I and Phase II Recharge Projects. The Optimum Basin Management Program Environmental Impact Report was approved on June 29, 2000. It identified no significant adverse impact to water quality as a result of the use of recycled water.
9. The Board has notified IEUA, CBWM, and other interested agencies and persons of its intent to amend water recycling requirements for the discharge and has provided them with an opportunity to submit their written views and recommendations.
10. The Board, in a public meeting, heard and considered all comments pertaining to the use of recycled water.

**IT IS HEREBY ORDERED** that Order No. R8-2007-0039 be amended as follows:

1. Recycled Water Quality Specification A.11. shall be replaced with the following:
  11. For each recharge basin, during the initial year of recharge operation after the Start-Up Period (See Provisions H.9), the maximum average RWC<sup>10</sup> and the TOC limit shall not exceed the maximum average RWC and TOC limits identified in the approved Start-Up Period report. After the first year following the Start-Up Period, the average RWC may be increased at each recharge basin. If the users propose to increase the maximum average RWC, prior approval shall be obtained from CDPH in accordance with CDPH Condition 4 of the Phase I and Phase II Reports (See Attachment A) and from the Executive Officer of the Regional Board. (See also Compliance Determination B.7.). If the approved maximum average RWC is exceeded, the Discharger shall implement measures such that the

maximum average RWC is reduced over a period of 120 months. IEUA shall maintain the RWC volume-based percentage as established and approved by CDPH in each of the basins start up plans. Also, IEUA shall maintain an ongoing assessment of the individual basin's soil aquifer treatment (SAT) efficiency and report any changes to an individual basin's SAT efficacy and the resulting RWC.

2. Compliance Determination B.7. shall be replaced with the following:
  7. Calculation of the running monthly average RWC shall commence after 30 months of operation and shall be based on the total volume of the recycled water and diluent water recharged over the preceding months. For each recharge basin, compliance with the current approved maximum average RWC shall be achieved no later than upon the completion of 120 months of operation after the start-up period. The average RWC shall be calculated by dividing the total volume of recycled water applied to the spreading area during the preceding 120 calendar months by the sum of the total recycled water applied to the spreading area and the diluent water applied during that 120-month period.
3. Conditions for Suspending Groundwater Recharge, E.5. shall be added as follows:
  5. IEUA shall suspend recycled water deliveries to a basin approved for recharge upon reaching the RWC limit on or after month 96 of the 120 month period. Prior to resuming recycled water deliveries, IEUA shall prepare and submit for review and approval a plan to achieve compliance with the RWC limit.
4. Required Notices and Reports F.20. shall be replaced with the following:
  20. The Discharger shall submit a RWC Management Plan to the CDPH and the Regional Board that includes estimates of future average RWCs based on anticipated recharge operations over the first 120 months of recycled water recharge at each recharge site. The RWC Management Plan shall be submitted with the Start-Up Period Report and updated with IEUA's annual report to the Regional Board during the first 120-months and shall clearly identify the plan to achieve compliance with the maximum recycled water contribution by the 120th month at each recharge site. IEUA shall update the basin-specific RWC plans annually to reflect the estimated diluent water and recycled water contributions for the upcoming year. For the purpose of the diluent water projections, implementation of a weighted averaging should be considered when it is known that imported water supplies will not be available for purposes of recharging the aquifer. The underflow of the Chino Basin aquifer may be used as a source of diluent water. CDPH may consider crediting a fraction of the flow as

diluent water, which would be dependent on the accuracy of the method used to measure the flow, its distribution, and the ability to meet the other diluent water criteria in the draft regulation.

5. Required Notices and Reports F.22 shall be added as follows:
  22. By March 1, 2011, the Discharger shall submit a written report based on the findings of a scientific peer review panel. The peer review panel will consist of at least one panel member experienced in the engineering, design, and operation of SAT systems and one research-oriented expert in the SAT field.
6. These amendments shall become effective upon the adoption of this Order.
7. All other conditions and requirements of Order No. R8-2007-0039 shall remain unchanged.

I, Gerard J. Thibeault, Executive Officer, do hereby certify that the forgoing is a full, true, and correct copy of an order adopted by the California Regional Water Quality Control Board, Santa Ana Region, on October 23, 2009.



---

Gerard J. Thibeault  
Executive Officer

THIS PAGE  
HAS  
INTENTIONALLY  
BEEN LEFT  
BLANK  
FOR PAGINATION



---

Date: April 21, 2010  
To: The Honorable Board of Directors  
Through: Public, Legislative Affairs and Water Resources Committee (04/14/10)  
From: Richard W. Atwater  
Chief Executive Officer/General Manager  
Submitted by: Martha Davis  
Executive Manager of Policy Development  
Subject: March Legislative Report from Geyer and Associates

---

**RECOMMENDATION**

This is an informational item for the Board of Directors to receive and file.

**BACKGROUND**

Bill Geyer and Jennifer West provide a monthly report on their state activities on behalf of IEUA.

**PRIOR BOARD ACTION**

None.

**IMPACT ON BUDGET**

None.

RWA:MD

Enclosure



THIS PAGE  
HAS  
INTENTIONALLY  
BEEN LEFT  
BLANK  
FOR PAGINATION



## MEMORANDUM

TO: Rich Atwater and Martha Davis  
FROM: Jennifer West  
DATE: April 5, 2010  
RE: March Legislative Report

---

Attached is the bill list for March. Most of the bills will be heard in their policy committees within the next two weeks.

IEUA continues to work with WaterReuse, other local governments and Senator Pavley's staff on proposed amendments to SB 918. The bill would require the California Department of Public Health to establish criteria for indirect potable reuse for groundwater recharge and surface water augmentation. The bill would also require a study be conducted to determine whether direct potable reuse is safe. As currently drafted, the bill's definitions of "indirect potable reuse" and "direct potable reuse" are inaccurate. There are also a host of other needed amendments. The bill will be heard in Senate Environmental Quality on April 19.

# Inland Empire Utilities Agency

April 5, 2010

Title	Summary	Status
<b>Delta/Delta Package Implementation</b>		
AB 1594 (Huber) co-authors Chesbro, Fong, Gaines, Torlakson and Yamada	<p>AB 1594 prohibits the construction of the PC, unless expressly authorized by the Legislature. It requires the Legislative Analysts Office (LAO) to prepare an economic analysis of the peripheral canal that includes 1) the total cost of the construction project, 2) expected impacts of the construction program on the taxpayers, water ratepayers and the General Fund.</p> <p>It also requires that the construction and operation of a PC, not diminish or negatively affect water supplies, water rights or water quality for "water users within the Delta watershed." This is an ambiguous, undefined term. AB 1594 is identical to AB 7X 13 introduced in the water special session.</p> <p><b>IEUA Opposed</b></p>	AWPW 4/13
AB 1677 (Caballero) Water Resources  (Amended 3-18)	<p>Extends the UWMP deadline for wholesale agencies to July 1, 2011 to allow for the development of the water conservation information from the retail agencies.</p> <p>Requires retail water suppliers to consider past water conservation practices by military installations in their services area.</p>	AWPA 4/13
AB 1780 (Yamada) Delta Stewardship Council	Spot bill on DSC	
AB 1788 (Yamada) Delta Flood	Authorizes the state to pay up to 70% of nonfederal cost if the flood control project benefits an area with a high household poverty rate.	A. Approps
AB 1797 (B. Berryhill) Delta Corridors	<p>Requires DWR to undertake an expedited evaluation and feasibility study to implementing a through-Delta conveyance plan known as the "Delta Corridors Plan."</p> <p>MWD, ACWA opposed because they believe the plan is out of date.</p>	AWPW 4/13
AB 1886 (Yamada) Delta Water use	Requires DWR in Bulletin 160 to include a report on actions to reduce reliance on the Delta water supplies.	A. Appros.

AWPW – Assembly Water, Parks and Wildlife Committee  
 ANR – Assembly Natural Resources Committee  
 SNRW – Senate Natural Resources and Water Committee

(amended 3-17)		
AB 2092 (Huffman) DSC fee	Would require the Delta Stewardship Council (DSC) to adopt a fee on SWP contractors and federal CVP to fund a portion of the planning and administration costs of the Council. The fee would be based on a reasonable estimate of the benefits received by the SWP contractors and the federal CVP. Fee would begin July 1, 2011. Also requires DSC to adopt a long term financing plan by January 2012 for implementing the Delta Plan.  ACWA opposed. Would like to spread to fee out to other beneficiaries of Delta water conveyance.	AWPW 4/13
AB 2336 (Fuller) Delta	Would require the Delta Stewardship Council, in the course of developing and adopting the Delta Plan, to assess the adverse impacts of predation on native species and recommend changes in law and actions by state agencies to remedy the situation. MWD sponsored	AWPW 4/13
AB 2405 (Buchanan) Delta Flood Control	Spot bill	
SB 808 (Wolk) Delta Levees	The bill extends the sunset on the current Delta Levee maintenance subvention program's 75%-25% reimbursement rate from July 1, 2010 to July 1, 2016. The DSC (Delta Stewardship Council) is required to develop priorities for levee investment as part of the Delta Plan, due Jan 1, 2012.	AWPW 4/27
SB 1468 (Padilla) Delta Vision	Spot bill on the BDCP.	
SB 1469 (Simitian) Delta beneficiaries (amended 3-23)	This bill would require DWR, by January 1, 2012, to identify all parties, including public and private parties, that benefit from waters originating in the Sacramento-San Joaquin Delta watershed and whose activities impact the Delta watershed. The bill would also require the department, by that date, to develop a process for determining the degree of responsibility attributable to each of the identified parties for physical and environmental impacts on the Delta.  This bill would require the department, by January 1, 2012, to estimate the infrastructure needs for the State Water Resources Development System over the next 30 years and the expected costs of associated environmental mitigation and restoration projects.	Rules
<b>Bond Funds</b>		

AWPW – Assembly Water, Parks and Wildlife Committee  
ANR – Assembly Natural Resources Committee  
SNRW – Senate Natural Resources and Water Committee

AB 1898 (Caballero) bonds	Intent language to create a priority list of infrastructure projects and to ensure adequate funding for those projects.	
AB 2146 (B. Berryhill) Water Resources	Makes technical changes to the Safe Drinking Water, Water Quality and Supply, Flood Control, River and Coastal Protection Bond Act.	Assembly
AB 2669 (M. Perez)	Allocates \$2 million from the Prop. 84 IRWM unallocated account for Riverside County waste water issues.	A. Enviro. Toxics
SB 991 (Wolk) Bonds funds	Appropriates \$569 million in bond funds from Prop. 84 and Prop 1E, including \$250 million for IRWM grants.	SNRW
SB 1013 (Denham) Prop. 204 funds	Spot bill	
SB 1014 (Denham) Prop 13	Spot bill	
<b>Water Conservation/Recycled Water</b>		
AB 1793 (Saldana) Turf	Prohibits common interest developments from prohibiting the installation of artificial turf.  Sponsored by San Diego County Water Authority	Asm Housing  4-14
AB 1704 (Jefferies) Water pipeline CEQA	Exempts recycled water pipelines and water pipelines from CEQA within an approved highway or street project.  WaterReuse, Western, ACWA in support.	Failed Passage
AB 1774 (Saldana) Recycled Water Irrigation  (Amended 3-24)	Would authorize a local agency to require a state agency to use recycled water for their landscape irrigation, as long as the recycled water was available and meet applicable water quality standards.  Sponsored by San Diego County Water Authority. MWD seeking amendments.	A. Approps.
AB 2163 (Mendoza) Graywater Systems	Spot bill	
AB 2277 (Fletcher) Water Conservation: Urban Retail Water Suppliers	Requires an urban retail water supplier that supplies water to that described military installation, for the purpose of preparing that implementation the UWMP, to consider the prior conservation of that military installation. Similar to AB 1677, as amended.	A. Approps.

AB 2409 (Nestande) Water Conservation in Landscaping Act	Requires any model ordinance and any ordinance adopted pursuant to the Water Conservation in Landscaping Act to exclude from the definition of the term water feature, swimming pools and spas.	AWPW 4-13
AB 2679 (Eng) Energy Water reduction	Would express the intent of the Legislature to enact a tiered system for achieving consumption reduction in energy and water.	
AB 2776 (Assembly WPW) Water Conservation: UWMP	Amends existing law requiring an urban water supplier to prepare and adopt, and update an urban water management plan. Grants such extension to an urban wholesale water supplier. Revises requirements that apply to a supplier that supplies water to a certain military installation by requiring the supplier to consider prior water conservation for the purpose of preparing that implementation plan.	AWPW
SB 918 (Pavley) Indirect Potable Reuse  (amended 3-18)	<p>This bill would require DPH to develop and adopt uniform water recycling criteria for indirect potable water reuse, both for groundwater and surface water augmentation, and investigate the feasibility of developing uniform water recycling criteria for direct potable reuse, consistent with a specified timeline.</p> <p>IEUA is working with WaterReuse on amendments that would only require DPH to develop and adopt criteria for surface water augmentation.</p> <p>Sponsored by PCL and WaterReuse.</p>	SEQ 4-19
SB 1173 (Wolk) Recycled Water  (amended 3-24)	<p>Makes it easier in SWRCB proceeding to force an entity to use recycled water, in lieu of potable water, when it is available and affordable. WaterReuse in support.</p> <p>ACWA not favor unless amended. They are concerned about the impact to groundwater users because the definitions in the bill are not clear. The latest amendments may have removed this concern. ACWA to reexamine the bill later this month.</p> <p><b>Recommend IEUA support</b></p>	S. EQ 4-19
SB 1234 (Kehoe) Water: Unreasonable Use	Requires the State Water Resources Control Board adopt regulations to identify unreasonable uses of water during various periods of water shortages.	SNRW
SB 1478 (Senate Natural Resources and	Grants the extension for adoption of an urban water management plan that is due in 2010 to an urban wholesale water supplier, and requires an urban water wholesale water	SNRW

AWPW – Assembly Water, Parks and Wildlife Committee  
ANR – Assembly Natural Resources Committee  
SNRW – Senate Natural Resources and Water Committee

Water Committee) Water Conservation: urban water management	supplier that adopts an urban water management plan in 2010 that does not include the specified technical methodologies to amend the plan. Revises the requirements that apply to an urban retail water supplier that supplies water to a specified military installation by requiring the supplier to consider the prior water conservation.	
<b>Water Quality</b>		
AB 1727 (Gilmore) Waste Discharge	Spot bill on waste discharge serious violations	
AB 1728 (Gilmore) Waste Discharge  (amended 3-18)	This bill would provide a publicly owned treatment works with the option of using an automatic composite sampler, in lieu of grab samples, to collect representative samples for monitoring constituents that are subject to the mandatory minimum penalties.	Ass. Toxics
AB 2107 (Fuller) State Water Pollution Control Revolving Fund	Makes technical, nonsubstantive changes to existing law that continuously appropriates state and federal funds in the State Water Pollution Control Revolving Fund to the State Water Resources Control Board for loans and other financial assistance for the construction of publicly owned treatment works.	Assembly
AB 2583 (Hall) Water Treatment	States that water agencies and their direct suppliers shall utilize raw material chemical products derived from Inherently Safer Technology, where appropriate given disinfection methodology used by the water agency, and are commercially available without being materially cost prohibitive to the water utilities or ratepayers.	Asm. Toxics
AB 2595 (Huffman) Waste Discharge waivers	Spot bill	
SB 1284 (Ducheny) Mandatory Minimum Penalties	States that failure to file a discharge monitoring report, if no discharge occurred during this time period, is not subject to a mandatory minimum penalty  ACWA sponsored.	S. Enviro. Quality
<b>CESA/NCCP/Fisheries</b>		
AB 2063 (Huffman) Fish: Chinook Salmon  (amended 3-15)	Amends the Salmon, Steelhead Trout, and Anadromous Fisheries Protection Act. Adds specified legislative findings and declarations. States the intent of the Legislature that the best available science and a life cycle analysis shall be utilized in determining where to focus conservation planning efforts for recovery of Chinook and other salmonoid species. Designates the Chinook salmon as the	A. Approps.

AWPW – Assembly Water, Parks and Wildlife Committee  
ANR—Assembly Natural Resources Committee  
SNRW – Senate Natural Resources and Water Committee

	official state anadromous fish.	
AB 2420 (Huffman) CESA	This bill would change the state-federal consistency provision within CESA, specifying that to receive "take" authorization for species, an applicant must meet all the requirements in the state law. DFG must also make a written finding, which is a new requirement, and will likely make the section less useful for applicants.  MWD, ACWA opposed	AWPW 4/13
SB 946 (Cogdill)	Spot bill streambed alteration agreements	
SB 1218 (Florez) Fisheries	Requires DFG to conduct a 3 year study to assess the interaction between hatchery fish and naturally spawned fish and to develop hatchery and stream management practices to ensure the viability of fish populations.	
SB 1294 (Hollingsworth) NCCP	Spot bill on NCCP	
SB 1334 (Wolk) NCCP	This bill would expand the cooperation requirements in the NCCP act to require the DFG to cooperate with <u>all</u> local agencies that have land use permit authority over the activities proposed to be addressed in the plan. The bill would require a corresponding finding.  MWD opposed because they believe the bill will make the planned NCCP/BDCP in the Delta more difficult to achieve.	SNRW 4-13
SB 1446 (Correa) CESA public agencies	CESA requires that party applying for a species "take" permit from DFG ensure adequate funding to implement CESA's minimization and mitigation measures and monitor compliance. This bill would require that an applicant that is a city, county, or other public agency be deemed to meet that funding requirement if the city, county, or other public agency complies with specified financial and accounting requirements and certifies that it will annually appropriate sufficient moneys to fund its minimization and mitigation obligations.	SNRW 4-13
<b>Water Rights/Supply/Delivery</b>		
AB 1834 (Solorio) Rainwater Capture (amended 3-25)	This bill would enact the Rainwater Capture Act of 2010, which would authorize a landowner to install, maintain, and operate, on the landowner's property, a rainwater capture system meeting specified requirements. The bill would require the State Water Resources Control Board to initiate a stakeholder process to develop guidelines for local agencies to address issues arising out of rainwater	AWPW 4-13

AWPW – Assembly Water, Parks and Wildlife Committee  
ANR – Assembly Natural Resources Committee  
SNRW – Senate Natural Resources and Water Committee



	capture for nonpotable uses, and would require the board to submit recommendations as to the appropriate guidelines to the Legislature and the Governor by December 31, 2011.	
AB 1843 (Gilmore) Water Security	Would require CA Office of Homeland Security to submit confidential reports to the Legislature on the current status of the state's drinking water systems and facilities with a focus on any vulnerability to terrorist attacks.	As. Gov. Org.
AB 1884 (Galgiani) Water supplies	Requires DWR to conduct a statewide inventory of local regional water supply projects and post the inventory on its website.	AWPW
AB 1975 (Fong) Water meters	Requires that water meters and or submeters be installed in multiunit residential structures after 2011 as a condition of new water service to that property.  Sierra Club Sponsor.	AWPW 4/13
AB 2049 (Arambula) Water Transfer	Prohibits a water transfer from agricultural to municipal users that lasts for 10 years or longer. The author is concerned about the impacts these transfers have on the agricultural community.  CBIA opposed	AWPW 4/13
SB 565 (Pavley) Water Rights	This bill attempts to insert several water rights provisions into law that were not agreed upon during negotiations in the fall. The bill increases fines for unauthorized diversions of water or failure to comply with a cease and desist order. It authorizes new fees for filing a statement of diversion. It authorizes SWRCB to require water users to perform and fund technical monitoring studies that could be used against the agency in a water right proceeding.  ACWA opposed.	AWPW
SB 934 (Cogdill)	Spot bill California Water Plan.	
<b>Local Government</b>		
AB 1676 (Fuentes) Local Elected Officials	This bill would require that a person elected to a state or local public office maintain his or her place of residence representing the voters in that district during his or her term of office. The bill would authorize a district attorney, a county counsel, or city attorney with enforcement authority to enforce a violation of these provisions.	Assembly Elections  4/6
AB 2080 (Hernandez) Bonds JPAs  (amended 3-18)	Expands Joint Power Authorities bond abilities with regard to the Buy America Bonds.	A Local Gov
AB 2207	States the intent of the Legislature to enact legislation to	Assembly

AWPW – Assembly Water, Parks and Wildlife Committee  
ANR – Assembly Natural Resources Committee  
SNRW – Senate Natural Resources and Water Committee

(Fong) Utilities: Termination of Services	create a statewide standard for the termination of household utility service, including electricity and gas, in order to protect vulnerable populations, as well as to prevent death and serious injury resulting from utility service termination.	
<b>Groundwater</b>		
AB 2304 (Huffman) Groundwater	Would add coordination with local planning agencies to develop and implement land use strategies that protect priority recharge areas to the list of authorizes components of a groundwater management plan.  Author is considering a variety of amendments.	AWPW 4/13 A Local Gov
<b>Miscellaneous</b>		
AB 1692 (Berryhill) State Agency Fines	This bill would require, notwithstanding any other law, that any fine or penalty imposed by the Department of Toxic Substances Control, the Division of Occupational Safety and Health in the Department of Industrial Relations, the State Air Resources Board, or the State Water Resources Control Board for a violation of a regulation adopted by that state agency be deposited into the General Fund.	ANR
AB 1929 (Hall) Mussels	Would provide that the operator of water delivery or storage facilities who has prepared a plan and initiates its plan to eradicate quagga mussels, as specifies, is not subject to civil or criminal liability.  ACWA/MWD sponsored  <b>Recommend IEUA Support</b>	Assembly Judiciary 4-06
AB 2256 (Huffman) Product Labeling: Flushable Products	Prohibits a person engaged in the packaging or labeling of a consumer product from distributing, or causing to be distributed a product, that is contained in a package, or that has an affixed label, that states that the product is flushable, sewer and septic safe, or other like term or phrase unless the product meets specified criteria. <b>IEUA Support</b>	A. Business and Professions
SB 894 (Senate Local Gov Omnibus Bill)	This bill would authorize an agency that owns and operates a reservoir used for drinking water, which amends its rules and regulations, to publish a summary of its amended rules and regulations, along with an Internet address and the physical location where the complete text of the amended rules and regulations may be viewed. EBMUD asked for this to be included in the bill.  ACWA in support	S. Local Gov.  4-21
<b>Climate Change/Cap and Trade</b>		

AWPW – Assembly Water, Parks and Wildlife Committee  
ANR—Assembly Natural Resources Committee  
SNRW – Senate Natural Resources and Water Committee

SB 1006 (Pavley) Climate Change	Would require the Natural Resources Agency in implementing climate change adaptation strategies to fully consider and undertake initiatives that protect or enhance natural ecosystems.  ACWA oppose unless amended.	SNRW 4-13
SB 1033 (Wright) GHG allowances	This bill would require CARB, if market-based compliance mechanisms are adopted (the cap and trade program), to sell, trade or otherwise distribute an allowance, defined as an authorization to emit greenhouse gas emissions, only to a person subject to the greenhouse gas emissions limit to which that allowance applies.	S. EQ 4-19

Date: April 21, 2010  
To: The Honorable Board of Directors  
Through: Public, Legislative Affairs, and Water Resources Committee (04/14/10)  
From: Richard W. Atwater  
Chief Executive Officer/General Manager  
Submitted by: Martha Davis  
Executive Manager of Policy Development  
Subject: March Legislative Report from Dolphin Group

---

**RECOMMENDATION**

This is an informational item for the Board of Directors to receive and file.

**BACKGROUND**

Michael Boccadoro provides a monthly report on the Dolphin Group's activities on behalf of the Chino Basin/Optimum Basin Management Program Coalition.

**PRIOR BOARD ACTION**

None.

**IMPACT ON BUDGET**

None.

RWA:MD

Enclosure

THIS PAGE  
HAS  
INTENTIONALLY  
BEEN LEFT  
BLANK  
FOR PAGINATION

March 31, 2010

**To:** Chino Basin/OBMP Coalition  
**From:** Michael Boccadoro  
President  
**RE:** March Status Report



---

Please find attached the status report from The Dolphin Group for the month of March 2010.

Despite a looming \$20 billion budget shortfall, Sacramento politicians appear content to await the Governor's May Revisé before making any significant movement towards addressing the problem. Legislators remain hopeful that tax receipts will improve during the spring, reducing the need to enact significant budget cuts to popular programs, including education. While revenues have indeed exceeded budgetary projections, expenses have increased even faster leading to a worsening fiscal situation.

Although state revenues are expected to be better under a somewhat improving economy, it is nearly certain that a significant budget shortfall will remain for the Legislature to address this summer. Conventional wisdom says that further tax increases will be difficult if not impossible to pass, particularly in an election year. The tax increases approved in 2008 are set to expire in early 2011, further exacerbating the budget shortfall.

On the regulatory front, the Governor and other Legislative leaders completed their appointments to the new Delta Stewardship Council. Also, the CPUC issued an important decision that reopens Direct Access, but having failed to begin implementing other programs such as the expansion of feed-in tariffs under SB 32, passed last year.

# Chino Basin / OBMP Coalition

## Status Report – March 2010

### ENERGY/REGULATORY

#### *Direct Access Returns*

After nearly a decade, the California Public Utilities Commission (CPUC) reopened Direct Access (DA) in the wake of the signing of Senate Bill 695 (Kehoe D-San Diego). DA is a program that permits customers to contract directly with third parties to purchase electricity. Distribution and transmission costs will still be paid to utilities such as SCE.

A product of the deregulation of 1996, at one point nearly 20% of all customers chose to purchase their electricity from energy service providers (ESPs) through DA. The other 80% remained with their utility, as so-called “bundled customers”. During the energy crisis of 2000-01, most DA customers returned to bundled service as energy services were better protected against skyrocketing wholesale energy prices at the time. All accounts that had a DA contract before September 20, 2001 are considered “grandfathered” and permitted, every three years, to opt back into direct access contracts if they choose.

This recent CPUC decision allows for a new set of customers to join these grandfathered accounts in opting for DA.

The following GWh of new direct access are permitted under the decision:

		<b>In gigawatt hours</b>		
		<b><u>SCE</u></b>	<b><u>PG&amp;E</u></b>	<b><u>SDG&amp;E</u></b>
1	Load Cap Pursuant to SB 695	11,710	9,520	3,562
2	Existing Base Line DA	7,764	5,574	3,100
3	<b>New DA Load Allowance</b>	<b>3,946</b>	<b>3,946</b>	<b>462</b>

This amount of new DA load will be permitted to enter the market over the next four years, beginning as early as April 11, 2010 and extending through 2013:

The annual kWh limits are as follows:

- Y1 (2010): 35% of the current room available under the DA cap. (Begins April 11, 2010)
- Y2 (2011): An additional 35% of the current room available under the cap
- Y3 (2012): An additional 20% of the current room available under the cap
- Y4 (2013): An additional 10% of the current room available under the cap

### *SB 32 Implementation Looks to Get a Late Start*

In late March, DGI held a number of meetings at the CPUC to inquire about the status of the implementation of SB 32 (Negrete-McLeod), which expands and improves the feed-in tariffs originally created by legislation sponsored by IEAU (AB 1969 – Yee).

Despite previous assurances that the CPUC would begin implementing SB 32 by March of this year, it was made apparent by the CPUC staff that the process wasn't likely to start for another 2-3 months, with final implementation not expected until Spring 2011. SB 32 went into effect on January 1, 2010.

In response, DGI has initiated conversations with various legislators and the Governor's office in order to expedite the implementation of this important piece of legislation. To date, CPUC staff has been busy implementing a parallel FiT program that uses a complicated pricing mechanism, and DGI, IEUA and other partners such as the solar industry have been pushing policy makers to ensure that SB 32 and standard feed-in tariffs are afforded similar attention and implementation as soon as possible.

This is of particular concern because the price paid for energy under the FiT fell this year by approximately 15%, while SB 32, when implemented, could possibly increase these prices. As a result, many small renewable projects are currently stalled given the prospect of potentially higher prices as SB 32 is implemented or other market changes occur. Compounding this issue is the fact that significant federal monies under the American Recovery and Reinvestment Act (ARRA) may be imperiled if not accessed by the end of the year (presumably before SB 32 would be fully implemented).

DGI and IEUA are committed to pushing for a speedy implementation of SB 32 within the next few months. These efforts are necessary to ensure that the market for small-to-medium sized renewable projects do not remain stalled and federal assistance is not wasted.

### *CPUC Hosts ACWA for Water/Energy Workshop*

On March 30, the Association of California Water Agencies held a joint workshop at the California Public Utilities Commission to discuss renewable energy efforts, energy efficiency projects, GHG reduction programs and how the water and energy sectors can better coordinate on the emerging nexus between water deliveries and energy usage.

Martha Davis of IEUA, serving as Chair of the ACWA Energy Committee was present. Discussions were held on Energy Efficiency Programs, renewable energy projects and how the water and energy sectors can work together on climate change and other issues.



## STATE BUDGET CRISIS REMAINS IN LIMBO

Two months after Governor Schwarzenegger submitted his proposed 2010-11 state budget, and just three months before the Legislature is required to adopt that budget, the Legislature was eerily quiet on budget matters in March.

Given the enormous scope of the \$20 billion shortfall, which only promises to increase in coming years as the temporary tax increases approved in 2008 expire next year, most Legislators appear content to await the Governor's May revise before significant debate continues.

This is largely due to the fact that the State Controller's office has reported better than expected tax receipts over the last few months. Most parties are content to see how much of the gap can be closed through these expanded revenues, thus tabling difficult decisions for at least a few months.

Few observers are confident that a budget agreement can be reached swiftly, almost certainly not by the July 1 beginning of the next fiscal year, a deadline seldom met by the Legislature over the last few decades.

## ENERGY-RELATED PROPOSITION ON JUNE PRIMARY BALLOT

The Pacific Gas & Electric Company, which serves most of Northern California, has qualified a Constitutional amendment for the June Primary ballot. The utility has already spent \$6.5 million on the campaign, and has committed to spending at least \$35 million to gain approval by voters.

The proposition would make the following changes:

- First, before an authorized local government entity can start up electricity service, it must receive approval by two-thirds of the voters in the area proposed to be served
- Second, before an existing publicly owned utility can expand its electric delivery service into a new territory, it must receive approval by two-thirds of the voters in the area currently served by the utility and two-thirds of the voters in the new area proposed to be served
- Third, the measure requires two-thirds voter approval for a local government to implement a community choice aggregation (CCA) program
- No election is required if the public agency will be providing 100% renewable power or if public funds are to be used to provide power solely to public agency facilities

Proposition 16 is a constitutional amendment, and could only be altered by another statewide vote.

Parties in support of Proposition 16 include the California Chamber of Commerce and the California Taxpayers Association. Proponents argue that by setting a "higher bar" for local

governments to enter some aspects of the energy business, it will protect citizens against agencies that might otherwise make unwise and risky decisions in those markets.

Groups in opposition include the Sierra Club, AARP, the Agricultural Energy Consumers Association, California State Association of Counties (CSAC), various environmental and renewable energy groups and a large swath of cities and counties. Groups in opposition argue that this initiative will essentially lock in utility monopolies, and make it nearly impossible for local communities and agencies to pursue alternatives to bundled monopoly service from their local investor-owned utilities.

### DELTA STEWARDSHIP COUNCIL MEMBERS NAMED

Final appointments to the seven-member Delta Stewardship Council were made in late March. The Governor's four appointees must be approved by the State Senate.

The council will begin work immediately to fulfill its legal mandate under SBX7-1, the law adopted in November that created the council. The first meeting is scheduled for April 1 in Sacramento.

#### Council Appointees named by the Governor:

**Randall "Randy" Fiorini** has been managing partner of Fiorini Ranch since 1975 and managing partner of FarmCo since 2001. Previously, he was president of Fiorini Family Vineyards from 2002 to 2008 and owner of Farm Data from 1984 to 2000. Fiorini is past president and board member of the Association of California Water Agencies, past board president and director of Turlock Irrigation District, and past president and board member of the California Farm Water Coalition. He earned a Bachelor of Science degree in fruit science from California Polytechnic State University, San Luis Obispo. Fiorini is a Republican.

**Philip Isenberg** has served as president of Isenberg/O'Haren Government Relations since 2005. From 1977 to 2004, he was counsel for Miller, Owens and Trost, Attorneys at Law. Previously, Isenberg served as a member of the California State Assembly representing the 9th District from 1992 to 1996 and the 10th District from 1982 to 1992. From 1975 to 1982, he was mayor of the city of Sacramento. Isenberg served as chair of the California Marine Life Protection Act Blue Ribbon Task Force from 2004 to 2006 and served as chair of the Delta Vision Blue Ribbon Task Force from 2007 to 2008. He is also a member of the Sacramento Valley Conservancy Advisory Board. Isenberg earned a Juris Doctorate degree from the University of California, Berkeley Boalt Hall School of Law and a Bachelor of Arts degree in social science and government from California State University, Sacramento.

**Henry "Hank" Nordhoff** was president and chief executive officer of Gen-Probe Incorporated from 1994 until his retirement in 2009. Currently, he serves as chairman. From 1992 to 1994, Nordhoff served as president and chief executive officer of TargeTech and, from 1988 to 1992, he was president and chief executive officer of American Biogenetic Sciences. From 1986 to 1988, Nordhoff was vice president of mergers and acquisition for Sterling Drug Company and from 1970 to 1986, he worked for Pfizer Inc. in the U.S., Europe and Asia. His last position at Pfizer was director of licensing and business development. Nordhoff earned a Master of Business Administration degree in international business and finance from Columbia University and a Bachelor of Arts degree in international relations and political economy from Johns Hopkins University. Nordhoff served in the U.S. Navy from 1963 to 1967. Nordhoff is a Republican.

Richard Roos-Collins has been director of legal services for the Natural Heritage Institute Since 1991. Previously, he served as deputy attorney general of the public rights division for the California Department of Justice from 1989 to 1991. From 1986 to 1989, Roos-Collins was attorney-advisor for the Office of the General Counsel at the U.S. Environmental Protection Agency. He is co-chair of the Agricultural Water Management Council and a member of the Bay Delta Conservation Plan Steering Committee. Roos-Collins is also director of the Pacific Forest and Watershed Lands Stewardship Council and founding director of the Hydropower Reform Coalition. He earned a Juris Doctorate degree from Harvard Law School and a Bachelor of Arts degree in English from Princeton University. Roos-Collins is a Democrat.

In addition to these four members, Senate Leader Darrell Steinberg nominated former state Sen. Patrick Johnston of Stockton to the council. From 1980-1990, Johnston served in the state Assembly and represented portions of the Delta along with areas of Sacramento and San Joaquin Counties. In 1990, Johnston was elected to the state Senate from the region, where he served until 2000. During that time, he chaired the Senate Appropriations Committee and served as a member of the Natural Resources and Wildlife Committee and the Agriculture and Water Committee. Johnston was the author of numerous bills on water, natural resources, and agriculture. In 1992, he authored the landmark Delta Protection Act (SB 1866 (Stats 1992, ch. 898), legislation that sought to preserve and protect the natural ecosystem and unique character of the Delta. Johnston is currently President of the California Association of Health Plans.

The state Assembly's designee was appointed by outgoing Assembly Speaker Karen Bass earlier in March. Gloria Gray is a former hospital administrator serving as a director of the Metropolitan Water District of Southern California and the West Basin Municipal Water District.

Don Nottoli, a Sacramento County supervisor, is automatically on the committee as head of the Delta Protection Commission.

A major part of the Delta Stewardship Council's mandate is writing and adopting a comprehensive "Delta Plan" to guide activities of more than 200 state and local agencies that have a regulatory role in the region. The council also must appoint a chief scientist to oversee a new science program.

The April 1 meeting is scheduled from 10 a.m. to 5 p.m. at the auditorium in the secretary of state's office, 1500 11th St. in Sacramento.

## LEGISLATURE PREPARES FOR HEARINGS

Following the mandatory 30 day holding period for all new bills that began in late February, the Legislature is prepared to gear up for a slew of policy committee hearings in April. All bills must be approved by their respective policy committees by May 7, and fiscal bills must be heard by April 23.

The following list represents the significant energy-related legislation introduced this year. It includes many "spot bills" which have not yet had substantive language amended into the bill.

- CA AB 1947      **AUTHOR:**                      Fong [D]  
                         **TITLE:**                              Solar Energy  
                         **INTRODUCED:**                      02/17/2010  
                         **LAST AMEND:**                      03/25/2010  
                         **DISPOSITION:**                      Pending  
                         **COMMITTEE:**                      Assembly Utilities and Commerce Committee  
                         **HEARING:**                              04/05/2010 3:00 pm  
                         **SUMMARY:**  
                         Authorizes a local publicly owned electric utility to adopt, implement, and finance a solar initiative program exempt from offset and same-premises program requirements, where residential and business consumers offset part or all of their electricity demand with electricity generated by a solar energy system not located on the premises of the consumer, if the program meets certain requirements.  
                         **Position:**                              Watch
- CA AB 1954      **AUTHOR:**                      Skinner [D]  
                         **TITLE:**                              Electrical Transmission: Renewable Energy Resources  
                         **INTRODUCED:**                      02/17/2010  
                         **DISPOSITION:**                      Pending  
                         **COMMITTEE:**                      Assembly Utilities and Commerce Committee  
                         **HEARING:**                              04/05/2010 3:00 pm  
                         **SUMMARY:**  
                         Relates to the Public Utilities Commission. Requires the commission, in acting upon an application by an electrical corporation for a certificate of public convenience and necessity, to deem new transmission facilities necessary to the provision of electric service, and the new transmission facilities facilitate achievement of the renewables portfolio standard. Requires the Commission to provide assurance of the eligibility for recovery.  
                         **Position:**                              Watch
- CA AB 2014      **AUTHOR:**                      Torrico [D]  
                         **TITLE:**                              Energy Efficiency  
                         **INTRODUCED:**                      02/17/2010  
                         **DISPOSITION:**                      Pending  
                         **LOCATION:**                              ASSEMBLY  
                         **SUMMARY:**  
                         Makes a nonsubstantive, technical change to existing law that requires a local publicly owned electric utility to be responsible for implementing an energy efficiency program that recognizes the Legislature's intent to encourage energy

savings and greenhouse gas emission reductions in existing residential and nonresidential buildings.

**Position:** Watch

CA AB 2037

**AUTHOR:** Perez V [D]  
**TITLE:** Electricity: Air Pollution  
**INTRODUCED:** 02/17/2010  
**DISPOSITION:** Pending  
**COMMITTEE:** Assembly Utilities and Commerce Committee  
**HEARING:** 04/05/2010 3:00 pm  
**SUMMARY:**

Prohibits a load-serving entity or local publicly owned electric utility from entering into, and would prohibit the Public Utilities Commission from approving for an electrical corporation, a long-term financial commitment with or for a new electrical generation facility that meets specified criteria, as determined by local air pollution control districts and air quality management districts.

**Position:** Watch

CA AB 2231

**AUTHOR:** Perez V [D]  
**TITLE:** Energy: Renewable Energy Action Team  
**INTRODUCED:** 02/18/2010  
**DISPOSITION:** Pending  
**COMMITTEE:** Assembly Natural Resources Committee  
**HEARING:** 04/12/2010 1:30 pm  
**SUMMARY:**

Convenes the Renewable Energy Action Team to develop and adopt the Desert Renewable Energy Conservation Plan to identify renewable energy zones based on renewable energy development potential and environmental, wildlife, and conservation criteria. Requires the commission to prepare a master environmental impact report or a program environmental impact report that encompasses all of the renewable energy resources that may be developed in the renewable energy zones identified in the plan.

**Position:** Watch

CA AB 2296

**AUTHOR:** Saldana [D]  
**TITLE:** Energy: Solar Energy Systems  
**INTRODUCED:** 02/18/2010  
**DISPOSITION:** Pending  
**COMMITTEE:** Assembly Utilities and Commerce Committee  
**HEARING:** 04/05/2010 3:00 pm  
**SUMMARY:**

Amends existing law regarding expansion of eligibility criteria for solar systems receiving ratepayer funded incentives including a solar energy system that is located on the same premises to include a near-site location to the end-use consumer.

CA AB 2378

**AUTHOR:** Tran [R]  
**TITLE:** Energy: Renewable Energy Program  
**INTRODUCED:** 02/19/2010  
**DISPOSITION:** Pending  
**COMMITTEE:** Assembly Utilities and Commerce Committee  
**HEARING:** 04/05/2010 3:00 pm  
**SUMMARY:**

Amends existing law that establishes the renewable energy resources program that is administered by the State Energy Resources Conservation and Development Commission to increase the amount of electricity generated from eligible renewable resources per year. Defines dual renewable energy device for the purposes of the program.

**Position:** Watch

CA AB 2431

**AUTHOR:** Fletcher [R]  
**TITLE:** Renewable Energy Resources  
**INTRODUCED:** 02/19/2010  
**DISPOSITION:** Pending  
**LOCATION:** ASSEMBLY  
**SUMMARY:**

Makes technical and nonsubstantive changes to existing law that requires the Public Utilities Commission to review and adopt a renewable energy procurement plan for each electrical corporation, pursuant to the Renewable Portfolio Standard Program.

**Position:** Watch

CA AB 2514

**AUTHOR:** Skinner [D]  
**TITLE:** Energy Storage Systems  
**INTRODUCED:** 02/19/2010  
**DISPOSITION:** Pending  
**COMMITTEE:** Assembly Utilities and Commerce Committee  
**HEARING:** 04/05/2010 3:00 pm  
**SUMMARY:**

Requires each electrical corporation and local publicly owned electric utility, to procure new energy storage systems, that are sufficient to provide specified percentages of the utility's average peak electrical demand using stored energy that was generated during offpeak periods of electrical demand.

**Position:** Watch

CA AB 2561

**AUTHOR:** Villines [R]  
**TITLE:** Energy: The Energy Commission and Department  
**INTRODUCED:** 02/19/2010  
**DISPOSITION:** Pending  
**COMMITTEE:** Assembly Utilities and Commerce Committee  
**HEARING:** 04/05/2010 3:00 pm  
**SUMMARY:**

Transfers various energy related powers, duties, responsibilities, obligations, liabilities, and jurisdiction to, from, and between specified existing and newly created energy planning and conservation agencies and boards. Repeals the Katz Safe Schoolbus Clean Fuel Efficiency Demonstration Program, the Small Business Energy Efficient Refrigeration Program, the State Solar Medallion Passive Design Competition and the Consumer Power and Conservation Financing Authority Act.

**Position:** Watch

CA AB 2679

**AUTHOR:** Eng [D]  
**TITLE:** Energy and Water: Consumption Reductions  
**INTRODUCED:** 02/19/2010  
**DISPOSITION:** Pending  
**LOCATION:** ASSEMBLY

**SUMMARY:**

Expresses the intent of the Legislature to enact legislation that creates a tiered system for achieving consumption reductions in energy and water in all public sector agencies for cost reduction, cost avoidance, and environmental compliance purposes.

**Position:** Watch

CA AB 2680

**AUTHOR:** Fong [D]  
**TITLE:** Public Utilities: Rates  
**INTRODUCED:** 02/19/2010  
**DISPOSITION:** Pending  
**LOCATION:** ASSEMBLY  
**SUMMARY:**

Makes technical, nonsubstantive changes to existing law that authorizes the Public Utilities commission to fix the rates and charges for every public utility in the state, and requires that those rates and charges be just and reasonable.

**Position:** Watch

CA AB 2693

**AUTHOR:** Blumenfield [D]  
**TITLE:** Local Government Renewable Energy Self-Generation  
**INTRODUCED:** 02/19/2010  
**DISPOSITION:** Pending  
**LOCATION:** Assembly Utilities and Commerce Committee  
**SUMMARY:**

Amends existing law which states the Public Utilities Commission has regulatory authority over public utilities, including electrical corporations, and that authorizes a local government to receive a bill credit to a designated benefiting account for electricity exported to the electrical grid by an eligible renewable generating facility. Revises the definition of a local government to include a joint powers authority or agency.

**Position:** Watch

CA SB 1153

**AUTHOR:** Hancock [D]  
**TITLE:** Global Warming: Renewable Energy: Agricultural Land  
**INTRODUCED:** 02/18/2010  
**DISPOSITION:** Pending  
**LOCATION:** Senate Rules Committee  
**SUMMARY:**

Expresses the intent of the Legislature to enact legislation to address the serious threat of global warming to the economic well-being and public health by coordinating permit approvals and providing incentives for renewable energy projects with multiple environmental and economic benefits to agricultural land.

**Position:** Watch

CA SB 1173

**AUTHOR:** Wolk [D]  
**TITLE:** Recycled Water  
**INTRODUCED:** 02/18/2010  
**LAST AMEND:** 03/24/2010  
**DISPOSITION:** Pending  
**COMMITTEE:** Senate Environmental Quality Committee  
**HEARING:** 04/19/2010 1:30 pm  
**SUMMARY:**

Defines raw water under the Porter-Cologne Water Quality Control Act. Declares

the use of raw or potable domestic water for nonpotable municipal or industrial uses is a waste or unreasonable use of water if recycled water is available. Prohibits a person or public agency from using raw or potable water that is suitable for nonpotable municipal or industrial uses if suitable recycled water is available. Includes irrigation of residential landscaping, floor trap priming, cooling towers and air-conditioning.

**Position:** Watch

CA SB 1198

**AUTHOR:** Huff [R]  
**TITLE:** Energy Resources Conservation and Development  
**INTRODUCED:** 02/18/2010  
**DISPOSITION:** Pending  
**COMMITTEE:** Senate Energy, Utilities and Communications Committee  
**HEARING:** 04/06/2010 9:30 am  
**SUMMARY:**

Requires the State Energy Resources Conservation and Development Commission to submit regulation that is adopted by the commission and which is not implemented by a specified date to the legislature before the regulation may be implemented. Prohibits a regulation that is adopted, but not implemented on or before a specified date, from being implemented until the state's unemployment rate remains at a certain rate for a specified number of months.

**Position:** Watch

CA SB 1241

**AUTHOR:** Wolk [D]  
**TITLE:** Greenhouse Gas Emissions Reduction  
**INTRODUCED:** 02/19/2010  
**LAST AMEND:** 03/25/2010  
**DISPOSITION:** Pending  
**COMMITTEE:** Senate Food and Agriculture Committee  
**HEARING:** 04/06/2010 10:00 am  
**SUMMARY:**

Requires the Secretary of Food and Agriculture and the Department of Food and Agriculture to administer an unspecified percentage of certain funds to be used for costs of administration or grants to reduce greenhouse gas emissions in the state's agricultural sector. Relates to the recusal by the membership of the Agricultural Climate Benefits Advisory Committee and violations for failure to do so.

**Position:** Watch.

CA SB 1247

**AUTHOR:** Dutton [R]  
**TITLE:** Renewable Energy Resources  
**INTRODUCED:** 02/19/2010  
**LAST AMEND:** 03/22/2010  
**DISPOSITION:** Pending  
**COMMITTEE:** Senate Energy, Utilities and Communications Committee  
**HEARING:** 04/20/2010 9:30 am  
**SUMMARY:**

Deletes the existing definition of renewable energy under the Renewables Portfolio Standard Program. Defines the term to mean an electric generating facility that uses biomass, solar energy, wind, geothermal, fuel cells using renewable fuels, hydroelectric generation, nuclear generation, digester gas, municipal solid waste conversion, landfill gas, ocean wave, ocean thermal, or



tidal current, and any additions or enhancements to the facility using that technology. Makes conforming changes to hydroelectric.

**Position:** Watch

CA SB 1248

**AUTHOR:** Dutton [R]  
**TITLE:** Public Utilities Act  
**INTRODUCED:** 02/19/2010  
**DISPOSITION:** Pending  
**LOCATION:** Senate Rules Committee  
**SUMMARY:**

Makes technical, nonsubstantive changes to existing law which states that the Public Utilities Commission has regulatory authority over public utilities.

**Position:** Watch

CA SB 1367

**AUTHOR:** Wyland [R]  
**TITLE:** Renewable Energy: Procurement Attainment Date  
**INTRODUCED:** 02/19/2010  
**DISPOSITION:** Pending  
**COMMITTEE:** Senate Energy, Utilities and Communications Committee  
**HEARING:** 04/20/2010 9:30 am  
**SUMMARY:**

Relates to the Portfolio Standard Program. Extends the target date for a retail seller to procure 20 percent of its retail sales from eligible renewable energy resources.

**Position:** Watch

CA SB 1465

**AUTHOR:** Lowenthal A [D]  
**TITLE:** Energy: Microturbines  
**INTRODUCED:** 02/19/2010  
**DISPOSITION:** Pending  
**COMMITTEE:** Senate Energy, Utilities and Communications Committee  
**HEARING:** 04/20/2010 9:30 am  
**SUMMARY:**

Amends the Waste Heat and Carbon Emissions Reduction Act. Requires an electrical corporation to purchase excess electricity from a customer of an electrical corporation that uses a microturbine with a generating capacity of not more than one megawatt that runs off waste or standard gas associated with the extraction of oil or gas and has a time-of-use meter capable of registering the flow of electricity in 2 directions.

**Position:** Watch



---

Date: April 21, 2010  
To: The Honorable Board of Directors  
Through: Public, Legislative Affairs, and Water Resources Committee (04/14/10)  
From: Richard W. Atwater  
Chief Executive Officer/General Manager  
Submitted by: Martha Davis  
Executive Manager of Policy Development  
Subject: March Legislative Report from Innovative Federal Strategies, LLC

---

**RECOMMENDATION**

This is an informational item for the Board of Directors to receive and file.

**BACKGROUND**

Letitia White provides a monthly report on their federal activities on behalf of IEUA.

**PRIOR BOARD ACTION**

None.

**IMPACT ON BUDGET**

None.

RWA:MD

Enclosure

THIS PAGE  
HAS  
INTENTIONALLY  
BEEN LEFT  
BLANK  
FOR PAGINATION

# *Innovative Federal Strategies* LLC

Comprehensive Government Relations

## MEMORANDUM

**To:** Rich Atwater and Martha Davis  
IEUA

**From:** Letitia White and Heather Hennessey

**Date:** March 31, 2010

**Re:** March Monthly Legislative Update

March was a crazy, crowded month on Capitol Hill! First and foremost, the month was very busy on the Hill due to the huge number of groups and delegations - - both large and small - - petitioning their federal representatives in the House and Senate. Petitioning our government or "lobbying" for our causes is the right given to each citizen by the First Amendment to the Constitution. Lobbying efforts on Capitol Hill predominantly had to do with health care reform and federal appropriations requests.

Second, there were many important legislative items which were addressed in Congress this month, including much debate and discussion on health care and "jobs" legislation. In addition, discussions surrounding three emergency supplemental appropriations bills - - one for the Federal Emergency Management Agency (FEMA), one for Haiti, and one for the wars in Iraq and Afghanistan - - have been underway. The cost of all these expensive items is very troubling to many budget conscious Members in the House and Senate as well as to the American public.

### ***Healthcare Overhaul***

On March 21, after fourteen months of taking up "all the air in the room", the House passed H.R. 3590, the Patient Protection and Affordable Care Act by a vote of 219-212, with no Republicans supporting the measure. (The Senate had passed the identical bill last December, by a vote of 60-39.) The House sent the bill to the President and he signed it into law with much fanfare on March 22, 2010. It is now known as Public Law 111-148.

Immediately after passing H.R. 3590, the House voted 220-211 to pass H.R. 4872, the Reconciliation Act of 2010, which made changes to the House and Senate-passed health care legislation. After defeating more than 30 Republican amendments, the Senate passed the reconciliation bill by a vote of 56-43 on March 25. But because of a few changes to the bill required by the Senate's "Byrd Rule", the House had to pass the bill again, which it did, also on March 25. The President signed the reconciliation bill into law on March 30.

Some of the major provisions in the healthcare reform bill include the following:

## *Innovative Federal Strategies LLC*

### **Coverage**

The legislation would extend coverage to 94% of all Americans. Those who do not receive health care coverage through their employer will be eligible to purchase coverage at group rates through the new health insurance exchange.

### **Tax Changes**

A middle-class tax cut for health care will provide middle class families with incomes up to \$88,000 for a family of four with tax credits to help pay for coverage in the exchange. Under the legislation, small businesses with 100 employees or less will be able to join the health insurance exchange, benefitting from group rates and a greater choice of insurers. Small businesses with 25 employees or less and average wages of less than \$50,000 will qualify for tax credits of up to 50% of the costs of providing health insurance. The new law will impose a tax on individuals without qualifying coverage of the greater of \$695 per year up to a maximum of three times that amount or 2.5% of household income to be phased-in beginning in 2014. Effective January 1, 2013, the law increases the Medicare Part A (hospital insurance) tax rate on wages by 0.9% (from 1.45% to 2.35%) on earnings over \$200,000 for individual taxpayers and \$250,000 for married couples filing jointly and imposes a 3.8% tax on unearned income for higher-income taxpayers (thresholds are not indexed).

### **Pre-existing Conditions**

Under the bill's insurance reforms, people with pre-existing conditions cannot be denied health coverage.

### **Costs**

The bill caps annual out-of-pocket costs at \$6,200 for individuals and \$12,400 for families who purchase insurance through the exchange or who are insured by small businesses. It also eliminates annual and lifetime limits on all insurance coverage.

### **Medicare**

The legislation provides Medicare beneficiaries free preventive and wellness care, improves primary and coordinated care, and enhances nursing home care. The bill also extends the solvency of the Medicare Trust Fund from 2017 to 2026. Additionally, under the legislation, Medicare beneficiaries affected by the donut hole will receive a \$250 rebate in 2010, 50% discounts on brand name drugs beginning in 2011, and complete closure of the "donut hole" within a decade. (The Medicare "donut hole" occurs when a Medicare beneficiary surpasses the prescription drug coverage limit. At that time, the Medicare beneficiary is financially responsible for the entire cost of prescription drugs until the expense reaches the catastrophic coverage threshold level.) A typical beneficiary who enters the donut hole will see savings of over \$700 in 2011 and over \$3,000 by 2020.

### **Community Health Centers**

Nationwide, the legislation would provide \$11 billion in new funding for these centers.

## *Innovative Federal Strategies LLC*

### **Young Adults**

The law allows young adults to remain on their parents' policies until they turn 26. For individuals under age 30, the bill creates new, less expensive policies that allow them to obtain protection from catastrophic health care costs.

### **Pell Grant Changes**

Included in the reconciliation bill (mentioned above) were wide-sweeping changes to the Pell Grant higher education federal loan program. The Student Aid and Fiscal Responsibility Act (SAFRA) comprehensively changes federal student lending by eliminating the use of private companies to write student loans and providing, instead, for direct federal loans. Beginning July 1, 2010, all new federal student loans will be originated through the Direct Loan program, instead of through the federally-guaranteed student loan program. The Direct Loans will be serviced by private lenders in the United States. SAFRA increases the maximum annual Pell Grant scholarship to \$5,550 in 2010 and to \$5,975 by 2017. Starting in 2013, the scholarship amount will also be indexed to the cost-of-living. The \$36 billion over ten years provided by this change includes \$13.5 billion to fund a shortfall in the Pell Grant scholarship program due to increased demand for the scholarship.

### ***FY2011 Appropriations Earmarks***

On Wednesday, March 20, David Obey (D-WI) Chairman of the House Appropriations Committee and Norm Dicks (D-WA), the new Chairman of the House Defense Appropriations Subcommittee, announced that the House Appropriations Committee would not consider requests for earmarks in Fiscal Year 2011 appropriations bills that are directed to for-profit entities.

The next day, on March 11, by voice vote in their private Conference meeting, the House Republicans took this "earmark reform" one step further and banned all House Republicans from submitting earmark requests in Fiscal Year 2011. This year-long moratorium includes not only appropriations but authorizing legislation as well.

This is very disappointing news! Yet, as you know, this is an election year and strange things are bound to happen. We expect the issue of earmarks to be revisited following the mid-term elections this November. Also, it is more than likely that many of the FY11 appropriations bills will not pass until *after* the elections.

It is very important to keep in mind that the for-profit and total earmark ban proposals are only in the House. The Senate will continue to earmark appropriations bills; Senate Appropriations Committee Chairman Daniel Inouye (D-HI) and Ranking Member Thad Cochran (R-MS) both came out in strong support of the Congressional privilege and responsibility to earmark legislation. They have both been staunch supporters in the past of the Constitutional right of Congress to allocate federal funds. Thus, we will be working hard to advocate for your projects in the Senate. We will point out to the Senate offices why it is now vital for their Senator to support us.

## *Innovative Federal Strategies LLC*

We are also working to see how we might be successful through other opportunities to communicate your projects directly to Agencies. Grant opportunities will also be another important focus. We will keep you posted.

### ***Jobs Bill***

Creating and retaining jobs is a huge part of the Democratic Majority party's agenda. The House and Senate have been working on a variety of proposals and will no doubt make them top priority now that the health care bills are completed. But, at this point, only one jobs bill - - the Hiring Incentives to Restore Employment (HIRE) Act - - has been signed into law by President Obama. The Hiring Incentives to Restore Employment (HIRE) Act, which was signed on March 18, will do the following:

- 1.) Provide tax cuts for businesses that hire someone who has been out of work for at least two months;
- 2.) Help businesses to invest in their future by permitting them to write off investments in equipment this year;
- 3.) Encourage job creation by expanding investments in schools and clean energy projects; and
- 4.) Maintain investments in roads and bridges.

Please let us know if you have any questions on these items or any other legislation.



---

Date: April 21, 2010  
To: The Honorable Board of Directors  
Through: Public, Legislative Affairs, and Water Resources Committee (04/14/10)  
From: Richard W. Atwater  
Chief Executive Officer/General Manager  
Submitted by: Martha Davis  
Executive Manager of Policy Development  
Subject: March Legislative Report from Agricultural Resources

---

**RECOMMENDATION**

This is an informational item for the Board of Directors to receive and file.

**BACKGROUND**

Dave Weiman provides a monthly report on his federal activities on behalf of IEUA.

**PRIOR BOARD ACTION**

None.

**IMPACT ON BUDGET**

None.

RWA:MD



THIS PAGE  
HAS  
INTENTIONALLY  
BEEN LEFT  
BLANK  
FOR PAGINATION

# *Agricultural Resources*

635 Maryland Avenue, N.E.  
Washington, D.C. 20002-5811  
(202) 546-5115  
(202) 546-4472-fax  
[agresources@erols.com](mailto:agresources@erols.com)

March 25, 2010

## Legislative Report

---

**TO:** Richard W. Atwater  
General Manager, Inland Empire Utility Agency

**FR:** David M. Weiman  
Agricultural Resources  
LEGISLATIVE REPRESENTATIVE, IEUA

**SU:** Legislative Report, March 2010

**Highlights:**

- *Health Care Dominated Domestic Agenda Congress*
- *UN World Water Day Report – Water Recycling Touted*
- *Napolitano – IMAF Plan – Submitted to White House Following Delegation, Administration Meeting*
- *BuRec Budget Presented to House and Senate*
- *Drought Conditions/Water Supply*
- *News and Notes*
- *IEUA Working Partners*

*Health Care Dominated the Domestic Agenda.* Comprehensive health care reform overwhelmed and dominated the legislative and political agenda here in Washington this past month. Congress enacted two health care bills, taken together, reflect a new direction in health care. The votes were partisan – and the issues remain controversial. The bill and its consideration became the exclusive focus of attention by the Administration and the Congress for most of this month.

*The United Nations Co-Authored by Peter Gleick, Pacific Institute (CA) Issue New Report on Water, Released on Water Day – Recycling Touted.* The United Nations Environment Program (UNEP) released a new report, “Clearing the Waters: A Focus on Water Quality Solutions,” during the global World Water Day at celebrations in Nairobi. According to the report investment in safe water will have high returns in ensuring a healthy ecosystem and a healthy society. Peter Gleick, President, Pacific Institute, based in Oakland, CA co-authored the report. Among other things, the report touts, as part of the solution, multi-billion investments in water recycling.

*Napolitano Initiative – 1 MAF in New Water in California From Recycling, Water Conservation.* Last month, I reported on a highly spirited water meeting – primarily focused on the Delta – with CEQ, three cabinet members, both Senators and almost a dozen House Members. Following that meeting, Chairwoman Grace Napolitano submitted a proposal to Nancy Sutley, Chair, Council on Environmental Quality (CEQ).

The Napolitano proposal was crafted on the belief that there are “three zones” of the issue: first, what to do with this water year (how to address allocations given Court and drought limitations). The third zone is the “long-term” water plan – the Delta vision – embodied in the package of legislation developed in Sacramento and the pending bond. To Napolitano, that left a “gap.” She has consistently focused on the gap – the time period between the immediate water allocations in 2010 and the implementation of the long-term agenda – a period of 24-60 months. The

Chairwoman recommended that 1 MAF of new water be developed – throughout the State – by starting some 40 new projects and the funds be available for engineering, environmental and administrative compliance. She recommended that the Administration provide \$200 million, which would leverage another \$600-750 million from the Bond market.

Napolitano believes that these projects can be identified, selected, planned, constructed and be up and operational within five years – and that 1 MAF of new water would “stretch” existing supplies and cushion the State’s water supplies for a number of years. There has been no response from the Administration, but the proposal is actively being considered.

*BuRec Budget Presented to Congress.* Secretary Salazar and BuRec Commissioner, Mike Connor presented their budgets to House and Senate Committees this past month. The Commissioner was heavily criticized for failing to outlay stimulus funds allocated early last year. House members, Ds and Rs, asked tough questions. He explained that the Bureau lacked sufficient contract officers to process the funds to be outlayed – and added, now the problem has been addressed and is being corrected. Other members strongly criticized the relatively low request for Title XVI funding.

*Drought Conditions and Water Supplies.* Drought conditions throughout the West are

lessening. The rolling series of storms have made a difference. And, a new round of storms are predicted for the West Coast at the end of March. The USDA-NOAA Drought Monitor shows Southern California continues to be “free of drought” – for the second month in a row. State DWR state allocations remain low because of carry-over concerns and system constraints.

*News and Notes. Earmarks Waters Continue.* House Dems impose restrictions on earmarks House GOP oppose earmarks. Senate disagrees with both. Issue will continue to be debated. *Feinstein to Seek Energy and Water Appropriations Subcommittee in next Congress.* With pending retirements, Senator Feinstein might become Chair, Subcommittee on Energy and Water, in the next Congress. This funding subcommittee makes funding decisions for DOE, the Corps and the BuRec. *NRDC, Leading Environmental Groups, Supports Water Recycling.* NRDC announced support for recycled water in a recent blog entry. NRDC is a major “green” group in California water politics. *National Academy of Sciences Uphold Biological Opinions, Calls for More Studies.* In a high-profile report designed to review the NMFS Biological Opinion on the Bay Delta, the NAS science panel upheld the basic conclusions, but called for a series of additional studies. This was the first phase of a two-phase report. *BuRec Circulates Criteria for Title XVI, Call for Comments.* The Bureau of Reclamation released a newly developed “criteria” for the selection of Title XVI projects. Comments are due in mid-April. This is the third criteria from the Bureau in about five years. ACWA and WaterReuse are preparing comments for water users. *University of Nevada – Invests in Sewage to Energy Research.* The sewage-to-energy investments continue. The University of Nevada released a study on converting sewage to energy. It’s catching on.

*IEUA Continues to Work With Various Partners.* On an on-going basis in Washington, IEUA continues to work with:

- a. Metropolitan Water District of Southern California (MWD)
- b. Milk Producer's Council (MPC)
- c. Santa Ana Watershed Project Authority (SAWPA)
- d. Water Environment Federation (WEF)
- e. Association of California Water Agencies (ACWA)
- f. WaterReuse Association
- g. CALStart
- h. Orange County Water District (OCWD)
- i. Cucamonga Valley Water District (CVWD)
- j. Western Municipal Water District
- k. Chino Basin Watermaster
- l. Western Urban Water Coalition
- m. National Water Resources Association

THIS PAGE  
HAS  
INTENTIONALLY  
BEEN LEFT  
BLANK  
FOR PAGINATION



---

Date: April 21, 2010

To: The Honorable Board of Directors

Through: Public, Legislative Affairs and Water Resources Committee (04/14/10)

From: Richard W. Atwater  
Chief Executive Officer/General Manager

Submitted by: Sondra Elrod  
Public Information Officer

Subject: Public Outreach and Communications

---

### **RECOMMENDATION**

This is an informational item for the Board of Directors to receive and file.

### **BACKGROUND**

#### **April 2010**

- April 7, Employee Service Award luncheon, Event Room, noon
- April 9, Recycled Water dedication ceremony for Cintas Corporation, 10:00 a.m.
- April 10, Water Awareness Day, Cucamonga Valley Water District
- April 16, GIES dedication at Glenmeade Elementary School in Chino Hills, 9:00 a.m.
- April 16, IEUA 101 at Chino Senior Center, 10:00 a.m.
- April 17, Project Learning Tree Workshop, IEUA Event Room
- April 22. SAWPA's Conference, Disneyland Hotel, 8:30 a.m. to 4:00 p.m.
- April 22, IEUA Earth Day in the Park, 4:00 p.m. to 6:00 p.m.
- April 23 - 24, Director Santiago's SWP tour

#### **May 2010**

- May 1, Mill Creek Clean-up as part of Big Sunday, 8:00 a.m. to 5:00 p.m.
- May 2, Mill Creek Clean-up as part of Big Sunday, 8:00 a.m. to 5:00 p.m.

#### **August 2010**

- August 12, County of San Bernardino Water Conference, Ontario Convention Center

Outreach/Educational Inland Valley Daily Bulletin Newspaper Campaign

The monthly tips on ways to help conserve water continue to appear in our local newspapers each month.

Water Conservation Outreach

IEUA is continuing to work with conservation partners to plan the Regional Conservation message. The slogan is *Saving Water...It's the Right Thing to Do*. The movie theatre campaign will begin appearing on May 28, and run through the end of September.

Regional Conservation Outreach Campaign

- Ongoing monthly ¼-page ads in the Inland Valley Daily Bulletin, Champion Newspaper, Fontana Herald News, La Opinion, and Inland Empire Magazine.
- Ongoing water wise gardening classes.
- Billboards.

Agency Tours

Tours of RP-5 wastewater plant were given to Chino High School, Buena Vista High School, and Bonita High School during March. A tour of the Wetlands was given by IEUA's Site Administrator for participants at the Riverside International Drought Workshop.

Educational Updates

- IEUA participated in an Earth Day Event at Briggs Fundamental School in Chino. A booth was displayed where the students learned about the water cycle by participating in the water cycle bracelet activity.
- IEUA hosted the Travelling Art Show from MWD on March 30<sup>th</sup> - April 5<sup>th</sup>. This is an accumulation of the winners from MWD's Student Poster Contest. IEUA had three winners from their service area.

**PRIOR BOARD ACTION**

None.

**IMPACT ON BUDGET**

The above mentioned activities are budgeted in the FY 2009/10 Public Information Services budget.

**DRAFT PEACE II CEQA Schedule**

Version Date – (4/5/10)

(Dates meant to be approximate)

1/1/08—TDA will finish draft Project Description for review. It will describe the project and the major issues. WEI, IEUA and CBWM are expected to provide key input. (COMPLETE)

1/15/09—TDA will provide WEI with a list of supporting exhibits needed (tables, graphs, charts, etc.) (COMPLETE)

2/20/09—TDA will release draft Initial Study and Notice of Preparation. (COMPLETE)

3/11/09—IEUA/CBWM will hold a Scoping Meeting so other agencies (water mgt agencies and regulatory agencies) will identify their concerns. (COMPLETE)

11/11/09—WEI will perform any necessary modeling, such as overlaying the Peace II and DYY models and looking at water level impacts, and prepare a Report. (COMPLETE)

4/19/10—SEIR Document released for public for review for 45 days.

6/7/10—End of 45-day public review period.

6/21/10—TDA finishes responses to comments.

7/7/10—IEUA Board adoption.



THIS PAGE  
HAS  
INTENTIONALLY  
BEEN LEFT  
BLANK  
FOR PAGINATION



# CHINO BASIN WATERMASTER

## IV. INFORMATION

1. Newspaper Articles



## Ontario to negotiate \$5 million water rights purchase

By Liset Márquez, Staff Writer

Created: 03/28/2010 07:37:09 PM PDT

ONTARIO - City Council members have given the city manager the green light to negotiate a contract with Praxair to purchase \$4.9 million in water rights.

The agreement will provide Ontario with 426 acre-feet of water per year, plus another 233 acre-feet of stored water and 427 acre-feet of carry over water. Praxair has a plant in Ontario.

"It's both the underlying need of water supply and to plan for the future," said Marvin Shaw, utilities general manager for Ontario.

"In the last few years, you can see how the water supply has fluctuated."

Ontario has been proactive in replenishing its supply. In 2008, the city purchased water rights from Sunkist for \$24 million.

"It's part of the long-term planning for the city of Ontario with the adoption of the Ontario Plan earlier, which lays out the future growth in the city," Shaw said.

In the next 20 years, housing in the city will

grow from more than 45,000 to 104,000 units, according to projections. The population will jump from 173,000 to 360,000 and jobs from 103,394 to 326,000.

Providing and ensuring the water supply for the city, Shaw said, was a reason for the purchase.

Purchasing water rights also means the city would be less reliant on the State Water Project for its resources, he said. The project is a publicly built and operated water and power development and conveyance system.

While this year's rainfall has been good, Shaw said, that isn't always the case. The state has been struggling with a drought the past couple of years.

"Water is the gold of California, it's the future commodity and that's a scarce resource," Councilman Jim Bowman said. "California is a desert and without water it wouldn't be what it is today."

Securing water rights now helps the city's economic viability, Bowman said.

The city's growth will depend on being able to serve the needs of the development community, he said, and water is an important part of those needs.

That cannot take place unless the city secures the necessary water resources, Bowman said.

advertisement



UNIVERSITY of SAN FRANCISCO

End-to-End Training as It Should Be: 100% ONLINE!

Earn Your Master Certificate in Internet Marketing

- SEO & Paid Search
- Online Branding
- Web Analytics
- Internet Law
- Media Buying
- Social Media



1-800-268-9943  
USanFranOnline.com/FD

Print Powered By Dynamics

But Ontario has always been an anomaly, according to Bowman, who said the city has been proactive in planning ahead.

In 2008, the council approved a \$24 million agreement with Sunkist Growers Inc. to acquire 11.5 acres of land.

The 2008 agreement with Sunkist included 11.5 acres of land. At that time, council members said purchasing the property and the water rights ensured the "future of quality of life."

Earlier this month, the council approved the first step of the process for the Praxair deal, Shaw said.

To complete the rights transfer, City Manager Chris Hughes must finish negotiations with Praxair and complete an approval process with Chino Basin Watermaster, which oversees the Chino Groundwater Basin.

The city manager still has to negotiate the deal as well as go through a process with Chino Basin Watermaster, which facilitates the use of the Chino Groundwater Basin, for the rights transfer.

Shaw said he doesn't expect that process to be completed until the summer.

"As long as its affordable, we will continue to look," Bowman said. "It's smart planning, we don't want to wait until the emergency is upon us, we always plan for an emergency."

advertisement



UNIVERSITY of  
SAN FRANCISCO

End-to-End Training as It Should Be: 100% ONLINE!

Earn Your Master Certificate in Internet Marketing

- SEO & Paid Search
- Online Branding
- Web Analytics
- Internet Law
- Media Buying
- Social Media



1-800-268-9943  
USanFranOnline.com/FD

Print Powered By Dynamics

# Chino Valley dairies face industry crisis

### Oversupply hurting prices

Neil Nisperos, Staff Writer

Created: 03/03/2010 05:51:35 PM PST  
Chino dairyman Syp Vander Dussen calls the two-year lull in milk prices absolutely devastating to his operations.

He's not alone.

Dairy farmers in the Inland Valley and throughout California have felt the sting from the price dip, which stems from overproduction, reduced global demand and the higher cost of grain feed.

The dairy farmers are facing another year of 1970s prices for their milk and payments up to 50 percent less than several years ago, according to the National Family Farm Coalition.

As a result, thousands of dairy farmers have gone out of business and thousands more are on the brink of closure.

"On average, all the profits and gains made in the (previous) five years has been lost in the past five years," Vander Dussen said.



Dairy farmers, like the one in Ontario that owns these cows, are facing another year of milk prices below production costs, according to the National Family Farm Coalition. (Will Lester/Staff Photographer)

Projections for 2010 show more low prices, as the cost to produce the milk is outpacing milk sale revenues.

"Starting in the fall of 2008, milk production

Advertisement

**End-to-End Training as It Should Be: 100% ONLINE!**

**Earn Your Master Certificate in Internet Marketing**

- SEO & Paid Search
- Online Branding
- Web Analytics
- Internet Law
- Media Buying
- Social Media

→ **1-800-268-9943**  
[USanFranOnline.com/FD](http://USanFranOnline.com/FD)

Print Powered By Dynamics

# dailybulletin.com

began to collapse," said Rob VandenHeuval, general manager of the Milk Producers Council, a dairy industry policy organization based in Chino.

"The price of milk dropped below the cost to produce the milk, and it's been that case month in and month out for the past 18 months. As long as any dairyman has been alive, it's never been this bad."

VandenHeuval said there are about 60 dairies operating in the Chino Valley.

In 2007, a weak dollar and a dairy shortage from Australia and New Zealand helped increase production because of increased global demand for U.S. milk.

Overproduction, decreased demand with the return of the Australian and New Zealand dairy industry, higher grain prices and a stronger U.S. dollar have fostered the situation that imperils the industry, VandenHeuval said.

"What happened was all of a sudden we had a global oversupply," he said. "We've had 18 months of scaling-back milk production. It's been a very slow process, and it's not easy for individuals to close up shop. In the past a lot of smaller dairies in the Midwest would close up shop, and we got the (supply) correction we needed. Now, people want to survive, not close, and they want to pass the dairy on to the kids, so it's much tougher for a supply correction."

Last year, Sen. Arlen Specter, D-Penn., introduced Senate Bill 1645, which would allow the cost of production for a farmer to be factored into the prices they receive. If approved, milk would be the only commodity of its kind to have a government-set price determined in part by the cost of production.

Milk Producers Council has introduced a herd retirement program in which farmers would be bought out in order to retire their herds. In the past 18 months, about 10 local dairies were closed through the program.

Vander Dussen said there would still be an oversupply of milk even with passage of the bill and since the herd buyout program is voluntary.

Vander Dussen suggested legislation be approved that would discourage dairymen from increasing production.

"Individually, shutting down makes no sense," Vander Dussen said. "With 1,500 producers in California, if you and I were to shut down, it won't affect the state price," he said. "It has to be across the board and it has to be industry-wide."

*The Associated Press contributed to this report.*

Advertisement



End-to-End Training as It Should Be: 100% ONLINE!

Earn Your Master Certificate in Internet Marketing

→ SEO & Paid Search	→ Internet Law
→ Online Branding	→ Media Buying
→ Web Analytics	→ Social Media

1-800-268-9043

USanFranOnline.com/ED

Print Powered By



# Australia provides lessons on water

Rebecca Kimitch, Staff Writer

Created: 03/09/2010 08:50:11 PM PST

To help California create beneficial water policies for the future, state water managers are turning for help to Australia and, ironically, to an area with close ties to the history of the Inland Empire.

Tim Brick, chairman of the Metropolitan Water District board of directors, and a delegation of California water leaders recently visited Australia to learn about water management in the face of drought and climate change.

And they went to an area in which an Inland Empire pioneer - George Chaffey - helped develop in the years after he founded the community of Ontario.

The Murray-Darling region was sparsely settled grazing land until the development of large-scale irrigation when Chaffey and his brother W. B. came there from California in 1887 and transformed the land into a rich agricultural region.

Australia has had to make dramatic changes in how it manages its scarce resource, from innovative use of technology to rationing to fundamental changes in how government manages water, said Jennifer McKay, professor

of business and water law at the University of South Australia.

Like California, Australia has met increasing demands for environmental protection, she said.

McKay spoke before a hearing of the Assembly's Select Committee on Regional Approaches to Addressing the State's Water Crisis this month in Sacramento.

"There was a crisis, and there was no choice but change. Fundamental change is possible, and now our system is quite set up to handle climate change," McKay said.

Committee chairman Jose Solorio, D-Anaheim, said it's important for California's water managers to see the strategies they struggle to implement "are very doable."

"We sometimes think we know it all in California. And there are times we don't. It is important to look to other states for their best practices, and every now and then it's good to look to other countries as well," he said.

Solorio pointed to Australia's success at reducing per-capita water use to 30 to 50 gallons a day, compared with about 180 gallons in California. Much of this savings has come from reducing and banning outdoor watering, capturing rainwater, installing dual plumbing in homes - one line for potable water and one line for recycled water, and mass use of water-efficient appliances and dual-flush toilets.

Advertisement

**USF UNIVERSITY of SAN FRANCISCO**

**End-to-End Training as It Should Be: 100% ONLINE!**

**Earn Your Master Certificate in Internet Marketing**

- SEO & Paid Search
- Online Branding
- Web Analytics
- Internet Law
- Media Buying
- Social Media

1-800-788-4943  
[USanFranOnline.com/ED](http://USanFranOnline.com/ED)

Print Powered By [logo]



Last year, California lawmakers passed legislation setting a goal of reducing urban water use by 20 percent by 2020.

"We are shameful in the volume of water we use in this state. It's embarrassing when we talk to people in other places around the world ... people fall out of their chairs when they hear how much water we use," said Wendy Martin, statewide drought coordinator for the Department of Water Resources.

Martin was also part of the recent delegation to Australia.

Although this year's rains might bring California's three-year drought to an end, the state's reservoirs are still dangerously low; its water sources are near ecological collapse; and climate change will fundamentally change water availability, Brick said.

Water managers are increasingly bracing for the impacts of climate change.

"The way climate change is going to hit most people is through water," Brick said.

Particularly concerning for California is the effect of climate change on snowpack levels and snowmelt times. Snowpack is the biggest storage device for the state - holding water for use during hotter summer months.

The National Academy of Science has forecasted

snowpack in the Sierra will drop by 29 percent by the end of the century. And those snows will continue melting earlier.

"What we view as drought in the Southwest is going to be normal in 30 years," Brick said.

California is going through a fundamental change in how it thinks about water, similar to what happened in Australia, Brick said.

For years, water agencies in Southern California have developed sophisticated and well-engineered systems to bring water from as far as Wyoming. The goal was to make residents unaware that the region "had a very serious problem with water," including periodic droughts, Brick said.

"We have worked so hard to almost deny the dry reality of California," he said. "In many ways, in Southern California, we are victims of our own success."

Brick estimates California is 10 years behind Australia in making significant changes.

In addition to slashing household use, Australian officials made across-the-board cuts for agricultural and industrial water use, using technology to improve efficiency in those areas as well.

"These guys really know how to do conservation, recycling, and stormwater management. They are world leaders in these areas. And there is

Advertisement

**End-to-End Training as It Should Be: 100% ONLINE!**

**Earn Your Master Certificate in Internet Marketing**

- SEO & Paid Search
- Online Branding
- Email Marketing
- Internet Law
- Media Buying
- Social Media

1-800-258-9849  
[www.usf-sanfranciscobulletin.com/PS](http://www.usf-sanfranciscobulletin.com/PS)

Print Powered By

Dynatrace





much for us to learn," Martin said. "And they have mastered desalination."

Every major city in Australia has built, or is building, a desalination plant.

Brick estimates this and other infrastructure investments have resulted in water costing twice what it does in California, with the cost there continuing to rise.

Although desalination projects are certainly in California's future - one is being built off the coast of Carlsbad - Brick said the state can still make up much ground in conservation before relying heavily on that costly technology.

Barry Nelson, a water policy analyst for the Natural Resources Defense Council, agreed.

"The abundance of waste we have in California compared to Australia means" it is more economical to conserve, he said.

Australia is the driest inhabited continent on Earth and has one of the lowest rainfall amounts in the world. Still, it has historically had fertile areas, particularly in the Murray-Darling river basin, that have made the country a major agricultural exporter.

The Chaffey's began at a sheep station at Mildura where a settlement was established in 1887. Despite rabbit plagues and other difficulties, the new town of Mildura grew and is today a major regional center of more than

50,000 people and is Upland's sister city.

The Chaffey's adapted the plan of Ontario to the present site of Mildura. They developed a series of steam-driven pumps to draw water from the Murray River to irrigate up to 33,000 acres.

Staff writer Joe Blackstock contributed to this report.

Advertisement



**End-to-End Training as It Should Be: 100% ONLINE!**

**Earn Your Master Certificate in Internet Marketing**

- SEO & Paid Search
- Online Branding
- Web Analytics
- Internet Law
- Media Buying
- Social Media

800.576.8043  
[SanFranOnline.com/ED](http://SanFranOnline.com/ED)

Print Powered By

Dynamic

THIS PAGE  
HAS  
INTENTIONALLY  
BEEN LEFT  
BLANK  
FOR PAGINATION

**dailybulletin.com**

## Cucamonga Valley sees water rate hike on horizon

Wendy Leung, Staff Writer

Created: 03/24/2010 05:24:21 PM PDT  
**RANCHO CUCAMONGA** - Eight months after the Cucamonga Valley Water District raised water rates due to increased costs of imported water, it is poised to hike rates about another 7 percent starting May 1.

Upgrades of two water treatment plants that officials say are necessary in order to meet new U.S. Environmental Protection Agency standards are part of the reason for the increase.

Officials from the district - which serves portions or all of Rancho Cucamonga, Upland, Ontario, Fontana and nearby unincorporated areas - estimate the upgrades to the Lloyd Michael and Royer-Nesbit treatment plants in Rancho Cucamonga could cost \$30 million over the next three years.

"Our rates have to ramp up to cover those costs," said Todd Corbin, assistant general manager at the district.

In addition to raising the water rate, the proposal also raises the sewer service fee and recycled water rate. A typical household that has paid an average water bill of \$106.20 every two months, would have to pay \$7.65, or 7.2 percent more, if the rate hike is passed. The proposal also calls for increases through 2014.

On April 27, the district will hold a public hearing about the changes. If passed by the agency's board, some increases will go in effect on May 1 and others July 1.

The proposal also introduces a tiered rate structure for commercial properties similar to that introduced in 2008 for residents. In a tiered structure, the water rate is highest for those who use the most water.

In addition to paying for the infrastructure projects, the planned rate hike will also help the district buy surplus water for groundwater storage. Corbin said it's in the district's interest to buy surplus water when the opportunities arise in order to secure the district's supply.

"It's cheaper for us to buy it now versus buying it later," Corbin said.

The board of directors is expected to vote

Advertisement



**Florida Tech**  
UNIVERSITY ONLINE

**Bring the Classroom to Your Home  
With a Degree Online From Florida Tech**

**APPLY TODAY!**  
FloridaTechOnline.com/FD | 1-888-253-5946



Print Powered By  Ezyne



on the rate increase on April 27. Customers can submit a written protest against the fee increase. If the majority of the district's customers, or about 26,400, submit a written protest, the rate can not be adopted. What: Public hearing on water rate increase

When: 6 p.m. April 27

Where: 10440 Ashford St., Rancho Cucamonga

Information: 909-944-6000, www.cvwdwater.com

Written protests of the water rate hike can be mailed to Secretary of the Board, 10440 Ashford St., Rancho Cucamonga 91730

Advertisement



**End-to-End Training as It Should Be: 100% ONLINE!**

**Earn Your Master Certificate in Internet Marketing**

- SEO & Paid Search
- Online Branding
- Web Analytics
- Internet Law
- Media Buying
- Social Media

→ 1-800-268-9943  
[SanFranciscoOnline.com/730](http://SanFranciscoOnline.com/730)

Print Powered By

Printed on